

# Centrifugal Fans

single inlet  
with direct drive

Issue 1.4  
July 2013

AIRTREND Ltd.  
Predstavništvo u Beogradu  
Kumanovska 14  
11000 Beograd  
Tel: 011 3836886, 3085740  
Faks: 011 3444113  
e-mail: [gobrid@eunet.rs](mailto:gobrid@eunet.rs)  
web: [www.airtrend.rs](http://www.airtrend.rs)

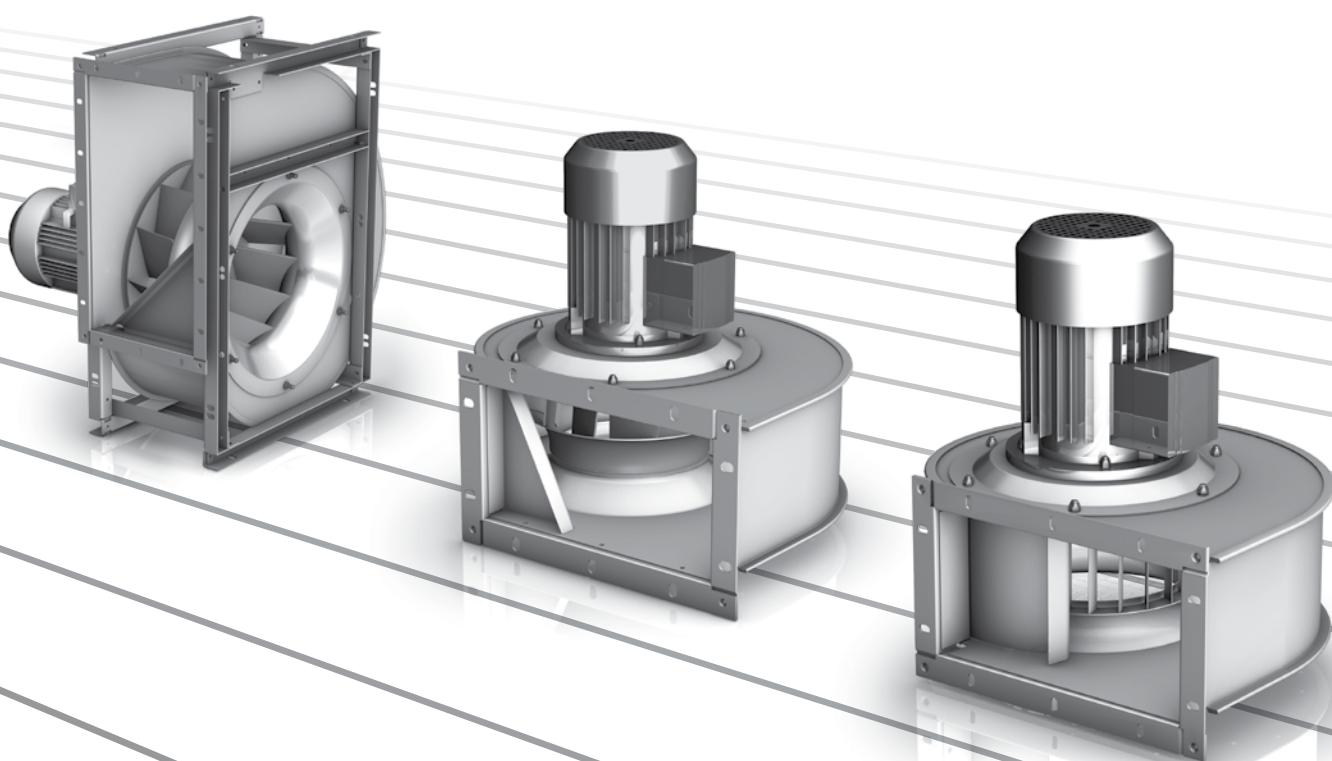

# The overall picture will decide

Depending on the model of the fan, the efficiency grade "N" set in accordance with the ErP Directive must be achieved from 2013 and 2015 respectively.

Efficiency grade "N" to ErP-Directive

Year	Centrifugal fans with backward curved blades			Centrifugal fans with forward curved blades	
	without housing static	with housing static	total	with housing static	total
2013	58	58	61	37	42
2015	62	61	64	44	49

The efficiency grade designates a parameter in the calculation of the target energy efficiency of a fan depending on the electric input power when operating at the optimal energy efficiency point. The figure of parameter "N" corresponds to the target energy efficiency with a power of 10 kW.

**To make the selection easier for our customers, we offer complete systems as defined by the ErP Directive!**

In order to compare the systems, the total efficiency  $\eta_e$  of the fan without speed regulation is considered.

$$\eta_e = P_{u(s)} / P_e$$

$\eta_e$  = Total efficiency  
 $P_{u(s)}$  = Fan gas power when operating at the optimal energy efficiency point  
 $P_e$  = Electric input power when operating at the optimal energy efficiency point

If the system has speed regulation, it will be taken into account with the "part load compensation factor"  $C_c$  (see below):

$$\eta_e = P_{u(s)} / P_{e(d)} \cdot C_c$$

$P_{ed}$  = Input power of speed regulator when operating at the optimal energy efficiency point  
 $C_c$  = part load compensation factor

- ▶ without speed regulation:  $C_c = 1$
- ▶ with speed regulation  $P_{ed} \geq 5$  kW:  $C_c = 1.04$
- ▶ with speed regulation  $P_{ed} < 5$  kW:  $C_c = -0.03 \ln(P_{ed}) + 1.088$

In order to take the speed regulation into account via the part load compensation factor  $C_c$ , the following mathematical losses arise in accordance with the formula prescribed by ErP for the following typical motor powers:

- ▶  $P_{ed} = 4.00$  kW:  $C_c = 1.05$  (5 %)
- ▶  $P_{ed} = 2.20$  kW:  $C_c = 1.06$  (6 %)
- ▶  $P_{ed} = 0.75$  kW:  $C_c = 1.10$  (10 %)

## Complete systems by Nicotra Gebhardt

Nicotra Gebhardt can supply complete systems in all product categories which meet the ErP requirements. We offer highly efficient fan systems

- ▶ with matching components and "high efficiency drives" – belt and direct drive.
- ▶ with integrated or external control to regulate speed.
- ▶ with IEC standard motors (IE2) or internal rotor motors with brushless DC technology.
- ▶ and with AC external rotor motors or brushless DC external rotor motors.

## Building blocks for best values

Thanks to the decades-long experience of Nicotra Gebhardt all the components of our fans contribute to their high performance.

Impellers and blades are optimised for turbulence and therefore particularly efficient. An example: With the latest development, the RLM Evo impeller, the free-running centrifugal fans of Nicotra Gebhardt achieve system efficiency grades never reached before.

In addition, the brushless DC drives which Nicotra Gebhardt offers for its direct drive fans improve the system efficiency grades.

**The fan technology of Nicotra Gebhardt delivers highly efficient systems for all applications.**

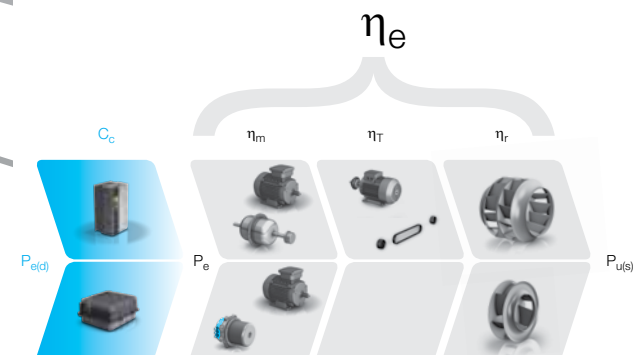



# proSELECTA II

proSELECTA II is a technical selection program that allows you to configure your own individually designed fan. It provides you with the opportunity to choose from the entire range of fan types and their associated options.



## Simple and reliable selection

The result from proSELECTA II is the provision of all the technical data for your fan, including sound level data, dimension specifications and accessories. Apart from that, as a registered user, your purchase prices are provided. Additionally fully dimensioned drawings in dxf format are available, which can be downloaded and transferred straight into your CAD system.

So that you can be sure. Models and options that are technically not permissible, are automatically excluded in proSELECTA II. So there is no chance that you will configure a "wrong" device option.

You can register as a proSELECTA II user with us, which enables us to offer you faster order processing. What this means for you is:

- ▶ The complete configuration of your fan with its associated system accessories and belt drive layout.
- ▶ The possibility to produce fans that operate via a frequency inverter.
- ▶ The option of saving your own fan configuration on our server.
- ▶ The opportunity to modify your saved configuration, even over the phone to your Nicotra Gebhardt representative.

## Nicotra Gebhardt technologies like ...

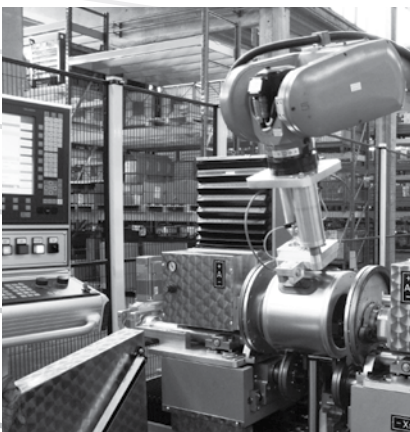

Automated manufacture of compact scroll and impeller with forward curved blades

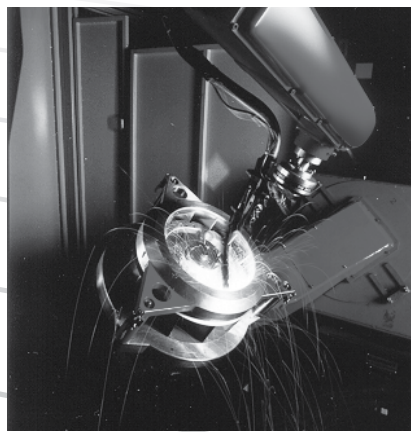

Own motor production for optimal tuning of motor and fan!



**High performance centrifugal fans TEM**

single inlet, with flanged IEC standard motor out of air stream, Impeller with forward curved blades of galvanised steel plate, with or without pedestal for horizontal or vertical mounting

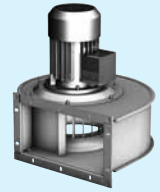
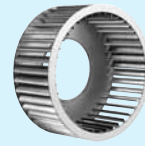

TEM

**High performance centrifugal fans REM 10**

single inlet, with flanged IEC standard motor out of air stream, Impeller with true airfoil blades, welded and painted, with or without pedestal for horizontal or vertical mounting



REM 10

**High performance centrifugal fans REM 40**

single inlet, with flanged IEC standard motor out of air stream, Impeller with backward curved blades, welded and painted, with or without pedestal for horizontal or vertical mounting



REM 40

**Fittings / Accessories**

- ▶ complete system accessories
- ▶ fittings and options



Fittings  
Accessories

**Technical Description**

- ▶ Descriptions
- ▶ Operating limits
- ▶ Notes

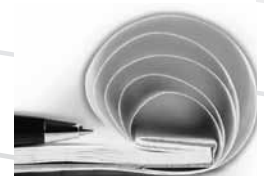

Technical  
Description

# Powerful centrifugal fans for universal use

## The product ranges TEM

The fan ranges TEM offered by Nicotra Gebhardt do present a large fan programme of single inlet centrifugal fans which are universally usable for many ventilation purposes either in HVAC or in machinery design industry and heavy duty installation business.

The fans are available with forward curved impellers.

The fans are equipped with IEC flanged (B5) standard motors, protection IP55, class F, and they are suitable for frequency inverter controlled operation.

### Benefits:

- ▶ compact design because of direct drive
- ▶ cost effective by maintenance-free operation
- ▶ speed controlled by frequency inverter
- ▶ universally usable due to different options, such as
  - ▶ without brackets as a directly fitted unit for operation with vertical shaft arrangement
  - ▶ with brackets for operation with horizontal shaft
- ▶ ATEX execution for explosion hazardous areas and applications  
Ex II 3G c IIB T3

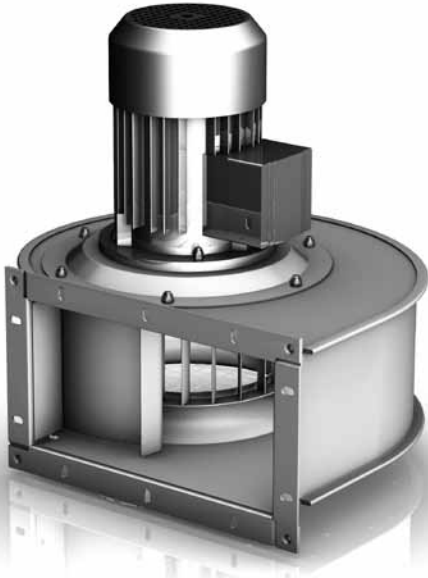



# The universal technology for various applications

## TEM ranges

- ▶ Sizes from 0160 up to 0355
- ▶ Volume flow up to 9000m<sup>3</sup>/h
- ▶ also available in 60Hz execution
- ▶ also available in ATEX execution 3G
- ▶ motor with PTC in flange execution
- ▶ Impeller with forward curved blades

For applications in HVAC-facilities, big kitchen or for clean room technology.

For every application, the suitable fan:

Version	Description	Figure
<b>TEM 01-0160/-0355</b>	Lap jointed scroll of galvanised sheet steel with discharge flange and built-in impeller with forward curved blades, without pedestal, for vertical or horizontal mounting.	
<b>TEM 08-0160/-0355</b>	Lap jointed scroll of galvanised sheet steel with discharge flange and built-in impeller with forward curved blades, with pedestal, for horizontal mounting.	

# TEM 01-0160

# TEM 08-0160

### Curves

- Operation limit, see Technical Data
- do not use in this area!

Density of media **1.2 kg/m<sup>3</sup>**.

Measured in installation **B** according to **ISO 5801** (ducted).

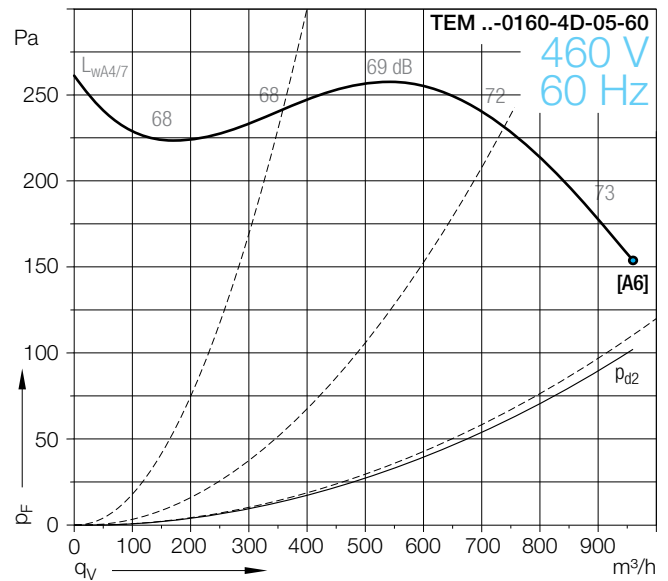
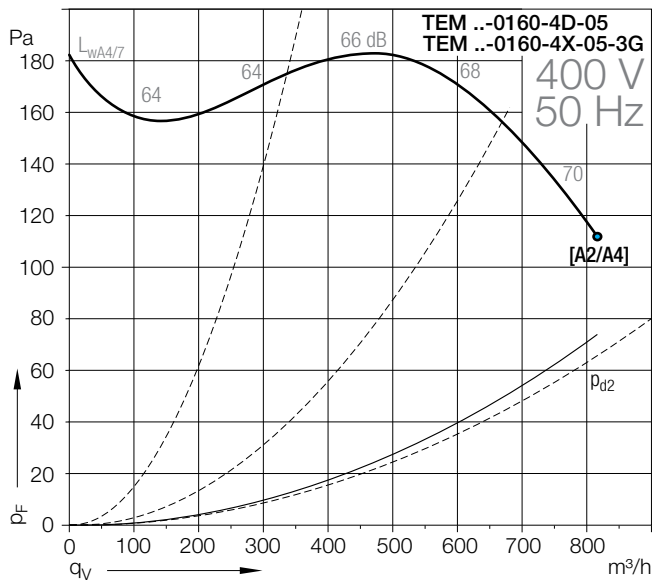
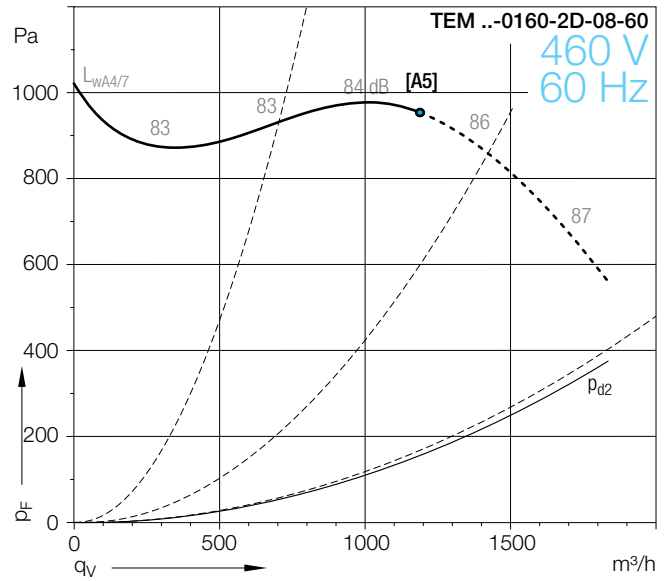
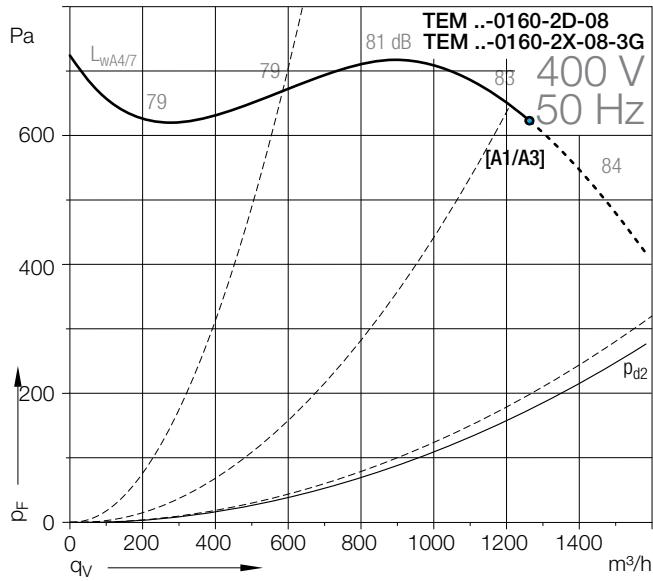
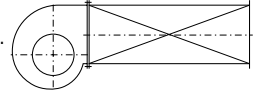

# TEM 01-0160

# TEM 08-0160

Technical Data												
TEM ..-	Curves	Nominal motor power kW	Poles	Motor size	Motor voltage V	Nominal frequency Hz	Connection	Nominal motor current A	Nominal motor speed 1/min	Max. media Temperature °C	Max. volume flow m³/h	Weight TEM 01/08 kg
0160-2D-08	[A1]	0.55	2	71	230/400	50	Δ/Y	2.35/1.36	2800	60	1270	10/13
0160-4D-05	[A2]	0.18	4	63	230/400	50	Δ/Y	0.97/0.56	1350	60	890	8/11

Ex II 3G c IIB T3 TEM ..-	Curves	Nominal motor power kW	Poles	Motor size	Motor voltage V	Nominal frequency Hz	Connection	Nominal motor current A	Nominal motor speed 1/min	Max. media Temperature °C	Max. volume flow m³/h	Weight TEM 01/08 kg
0160-2X-08-3G	[A3]	0.55	2	71	230/400	50	Δ/Y	2.40/1.40	2785	60	1270	10/13
0160-4X-05-3G	[A4]	0.18	4	63	230/400	50	Δ/Y	1.07/0.62	1330	60	890	8/11

  

60 Hz TEM ..-	Curves	Nominal motor power kW	Poles	Motor size	Motor voltage V	Nominal frequency Hz	Connection	Nominal motor current A	Nominal motor speed 1/min	Max. media Temperature °C	Max. volume flow m³/h	Weight TEM 01/08 kg
0160-2D-08-60	[A5]	0.63	2	71	460	60	Y	1.32	3400	60	1180	10/13
0160-4D-05-60	[A6]	0.21	4	63	460	60	Y	0.55	1650	60	1050	8/11

The given nominal motor current may not be exceeded. If the current consumption is exceeded, the volume is to be throttled correspondingly.  
 For fans of the ATEX execution, the guarantee for operation in explosion endangered areas or for the conveyance of explosive atmosphere expires when the motor nominal current is exceeded! For information on fans of the ATEX execution see Technical Description of this chapter.

Motor protection can take place through motor protection units with bi-metallic releases (EUM 33) or via a thermistor (NTC) temperature sensor in connection with a thermistor (NTC)-release device (EUM 03). See chapter "Accessories".  
 The direction of rotation is determined looking from the drive side. Anti-clockwise rotation, symbol **LG**. Clockwise rotation, symbol **RD**.

**Dimensions** in mm, subject to change.

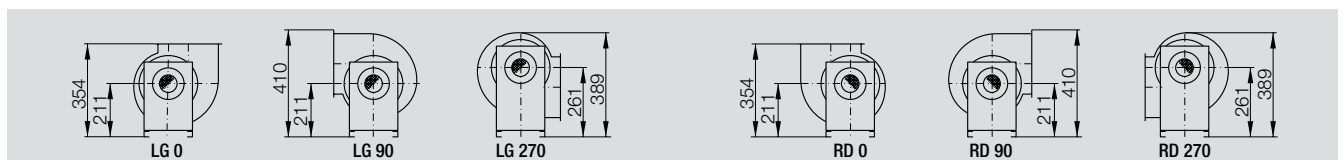
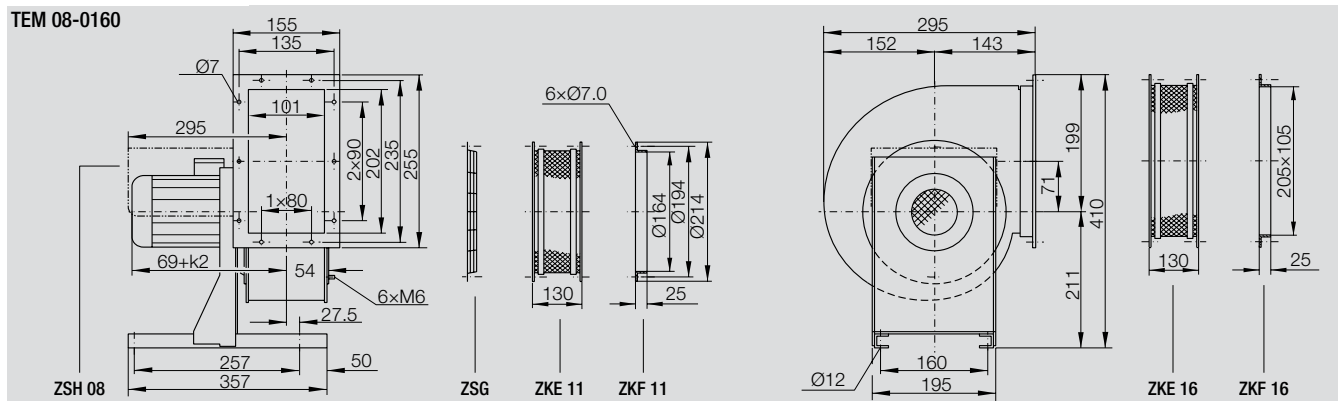
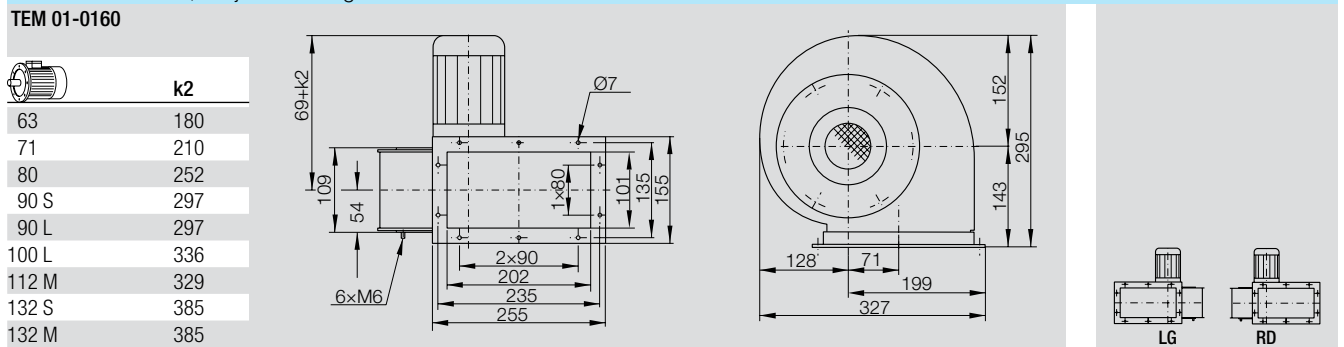

# TEM 01-0180

# TEM 08-0180

### Curves

- Operation limit, see Technical Data
- do not use in this area!

Density of media **1.2 kg/m<sup>3</sup>**.

Measured in installation **B** according to **ISO 5801** (ducted).

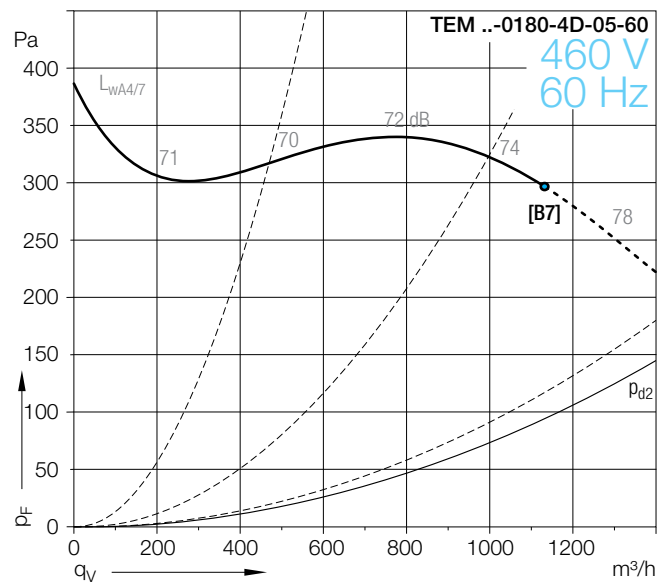
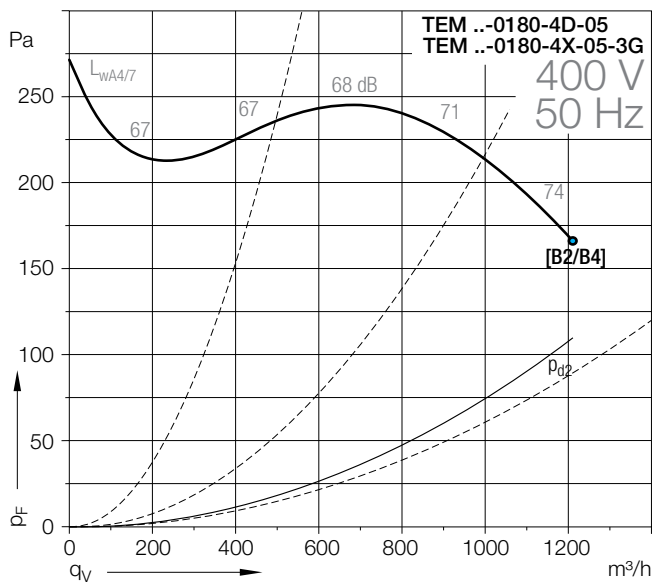
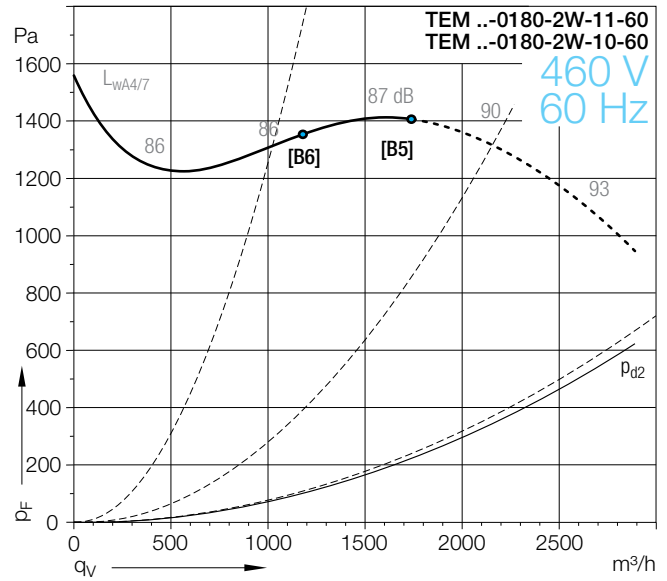
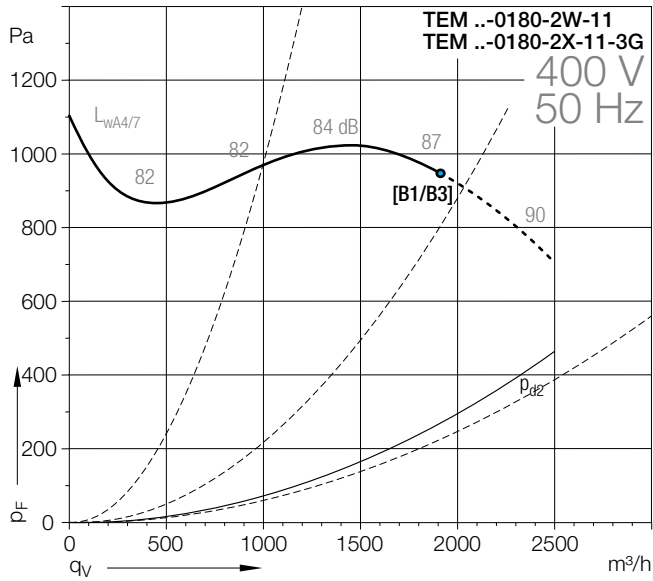
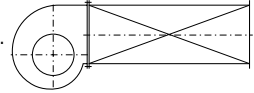



# TEM 01-0180

# TEM 08-0180

## Technical Data

TEM ..-	Curves	Nominal motor power kW	Poles	Motor size	Motor voltage V	Nominal frequency Hz	Connection	Nominal motor current A	Nominal motor speed 1/min	Max. media Temperature °C	Max. volume flow m³/h	Weight TEM 01/08 kg
0180-2W-11	[B1]	1.10	2	80 M	230/400	50	Δ/Y	4.20/2.40	2835	60	1950	13/17
0180-4D-05	[B2]	0.18	4	63	230/400	50	Δ/Y	0.97/0.56	1350	60	1250	8/12

Ex II 3G c IIB T3 TEM ..-	Curves	Nominal motor power kW	Poles	Motor size	Motor voltage V	Nominal frequency Hz	Connection	Nominal motor current A	Nominal motor speed 1/min	Max. media Temperature °C	Max. volume flow m³/h	Weight TEM 01/08 kg
0180-2X-11-3G	[B3]	1.10	2	80	230/400	50	Δ/Y	4.30/2.50	2855	60	1950	13/17
0180-4X-05-3G	[B4]	0.18	4	63	230/400	50	Δ/Y	1.07/0.62	1330	60	1250	8/12

60 Hz TEM ..-	Curves	Nominal motor power kW	Poles	Motor size	Motor voltage V	Nominal frequency Hz	Connection	Nominal motor current A	Nominal motor speed 1/min	Max. media Temperature °C	Max. volume flow m³/h	Weight TEM 01/08 kg
0180-2W-11-60	[B5]	1.27	2	80 M	460	60	Y	2.40	3402	60	1760	13/17
0180-2W-10-60	[B6]	0.86	2	80 M	460	60	Y	1.67	3366	60	1180	11/15
0180-4D-05-60	[B7]	0.21	4	63	460	60	Y	0.55	1650	60	1140	8/12

The given nominal motor current may not be exceeded. If the current consumption is exceeded, the volume is to be throttled correspondingly.  
 For fans of the ATEX execution, the guarantee for operation in explosion endangered areas or for the conveyance of explosive atmosphere expires when the motor nominal current is exceeded! For information on fans of the ATEX execution see Technical Description of this chapter.

Motor protection can take place through motor protection units with bi-metallic releases (EUM 33) or via a thermistor (NTC) temperature sensor in connection with a thermistor (NTC)-release device (EUM 03). See chapter "Accessories".  
 The direction of rotation is determined looking from the drive side. Anti-clockwise rotation, symbol **LG**. Clockwise rotation, symbol **RD**.

### Dimensions in mm, subject to change.

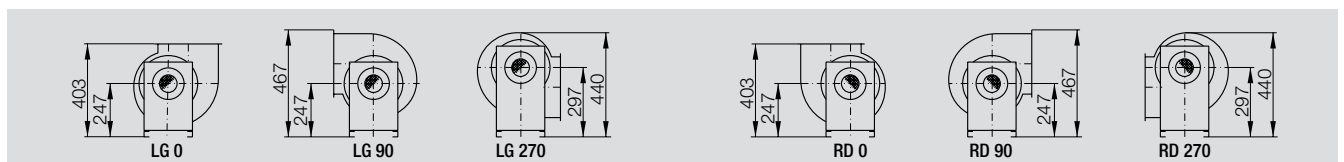
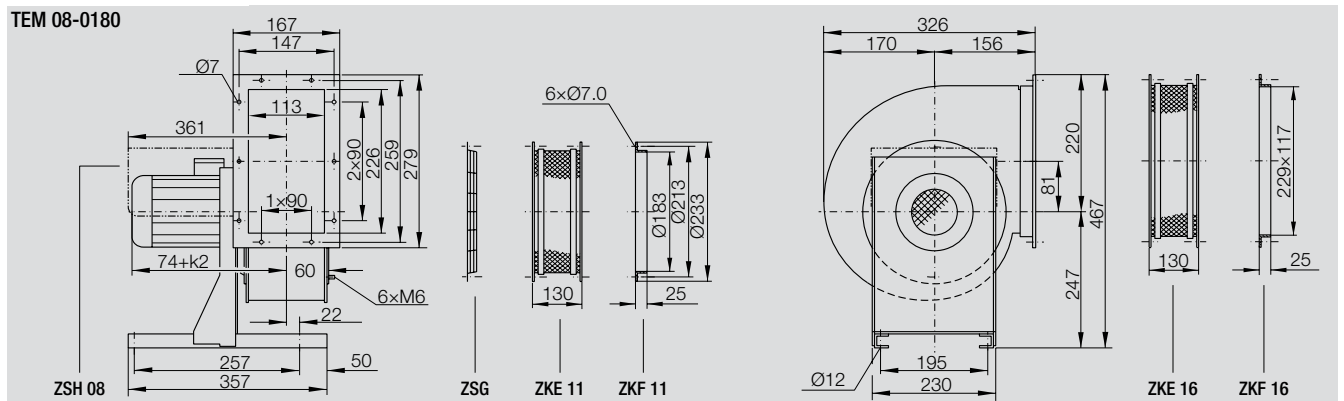
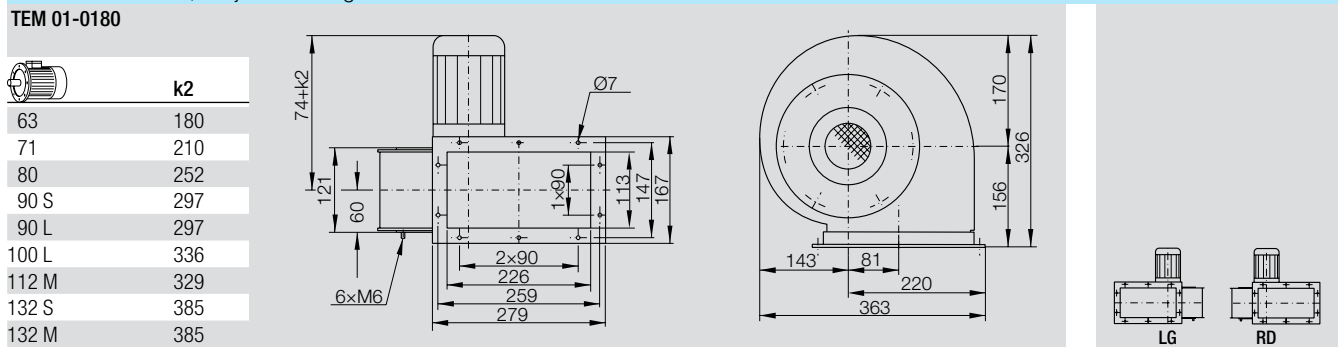

# TEM 01-0200

# TEM 08-0200

### Curves

- Operation limit, see Technical Data
- do not use in this area!

Density of media **1.2 kg/m<sup>3</sup>**.

Measured in installation **B** according to **ISO 5801** (ducted).

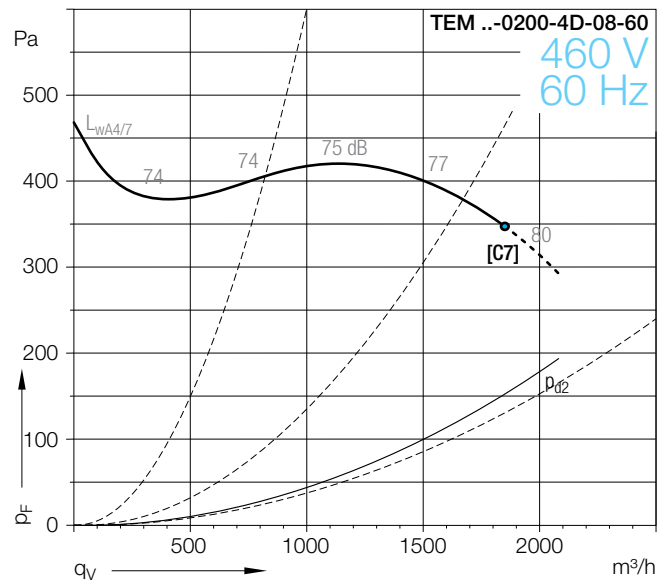
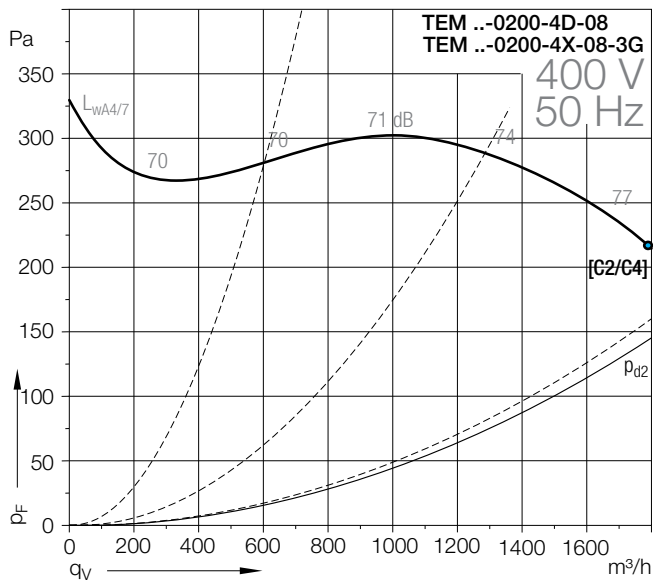
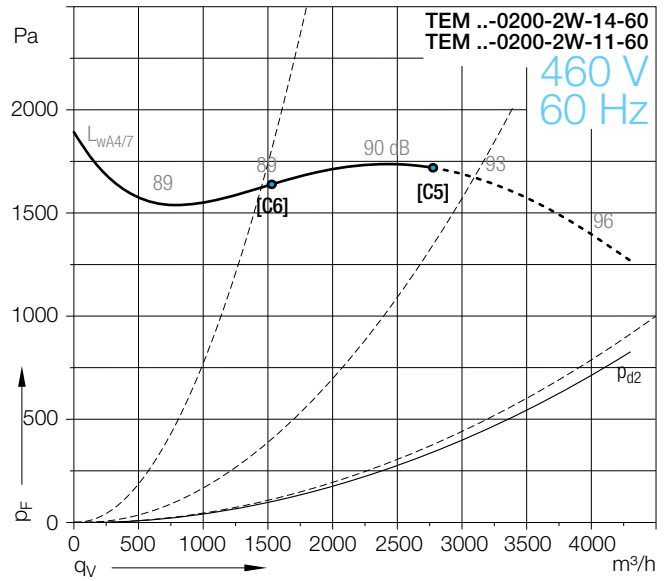
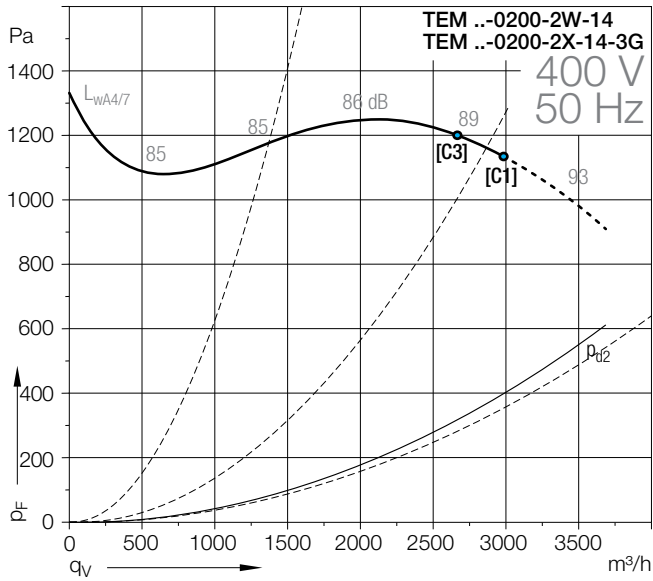
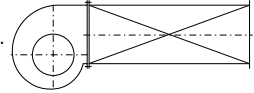

# TEM 01-0200

# TEM 08-0200

## Technical Data

TEM ...	Curves	Nominal motor power kW	Poles	Motor size	Motor voltage V	Nominal frequency Hz	Connection	Nominal motor current A	Nominal motor speed 1/min	Max. media Temperature °C	Max. volume flow m³/h	Weight TEM 01/08 kg
0200-2W-14	[C1]	2.20	2	90 L	230/400	50	Δ/Y	7.80/4.50	2890	60	2800	20/24
0200-4D-08	[C2]	0.37	4	71	230/400	50	Δ/Y	1.78/1.03	1370	60	1970	10/14

Ex II 3G c IIB T3 TEM ...	Curves	Nominal motor power kW	Poles	Motor size	Motor voltage V	Nominal frequency Hz	Connection	Nominal motor current A	Nominal motor speed 1/min	Max. media Temperature °C	Max. volume flow m³/h	Weight TEM 01/08 kg
0200-2X-14-3G	[C3]	1.85	2	90 L	230/400	50	Δ/Y	6.85/3.95	2865	60	2730	20/24
0200-4X-08-3G	[C4]	0.37	4	71	230/400	50	Δ/Y	1.91/1.10	1355	60	1970	10/14

60 Hz TEM ...	Curves	Nominal motor power kW	Poles	Motor size	Motor voltage V	Nominal frequency Hz	Connection	Nominal motor current A	Nominal motor speed 1/min	Max. media Temperature °C	Max. volume flow m³/h	Weight TEM 01/08 kg
0200-2W-14-60	[C5]	2.55	2	90 L	460	60	Y	4.50	3468	60	2820	20/24
0200-2W-11-60	[C6]	1.27	2	80 M	460	60	Y	2.40	3402	60	1510	14/18
0200-4D-08-60	[C7]	0.43	4	71	460	60	Y	1.02	1670	60	1870	10/14

The given nominal motor current may not be exceeded. If the current consumption is exceeded, the volume is to be throttled correspondingly.  
 For fans of the ATEX execution, the guarantee for operation in explosion endangered areas or for the conveyance of explosive atmosphere expires when the motor nominal current is exceeded! For information on fans of the ATEX execution see Technical Description of this chapter.

Motor protection can take place through motor protection units with bi-metallic releases (EUM 33) or via a thermistor (NTC) temperature sensor in connection with a thermistor (NTC)-release device (EUM 03). See chapter "Accessories".  
 The direction of rotation is determined looking from the drive side. Anti-clockwise rotation, symbol **LG**. Clockwise rotation, symbol **RD**.

### Dimensions in mm, subject to change.

**TEM 01-0200**

Motor size	k2
63	180
71	210
80	252
90 S	297
90 L	297
100 L	336
112 M	329
132 S	385
132 M	385

**TEM 08-0200**

# TEM 01-0225

# TEM 08-0225

### Curves

- Operation limit, see Technical Data
- do not use in this area!

Density of media **1.2 kg/m<sup>3</sup>**.

Measured in installation **B** according to **ISO 5801** (ducted).

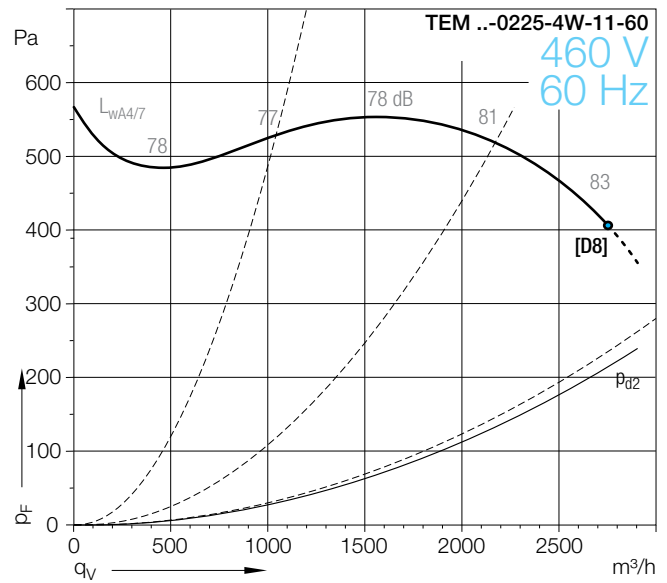
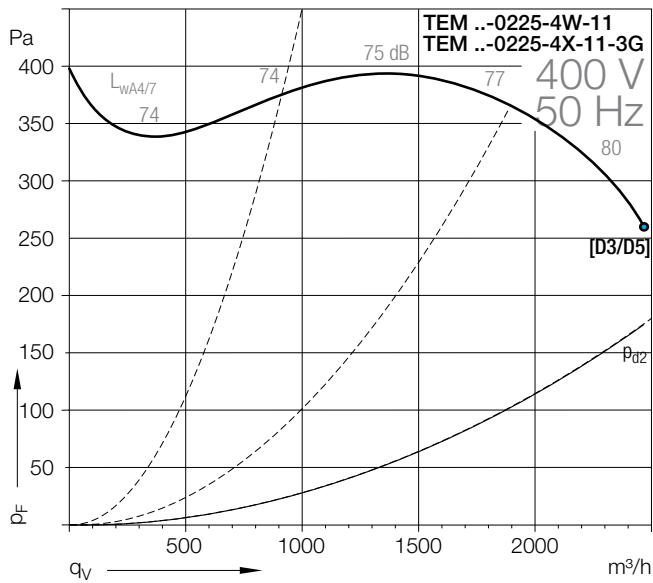
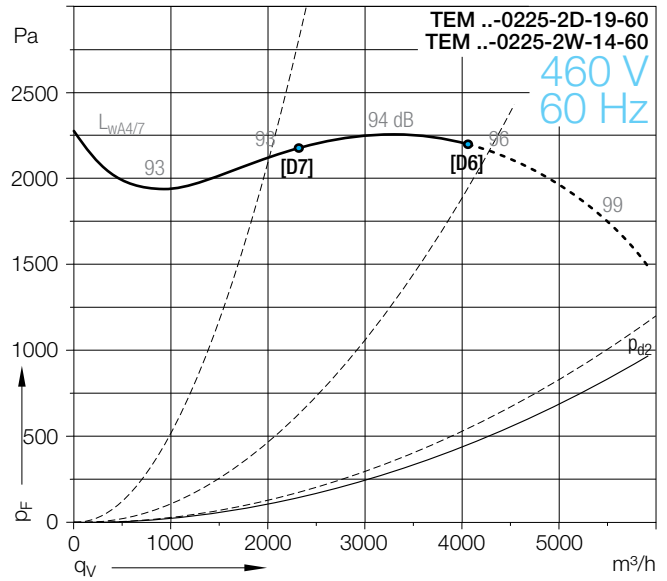
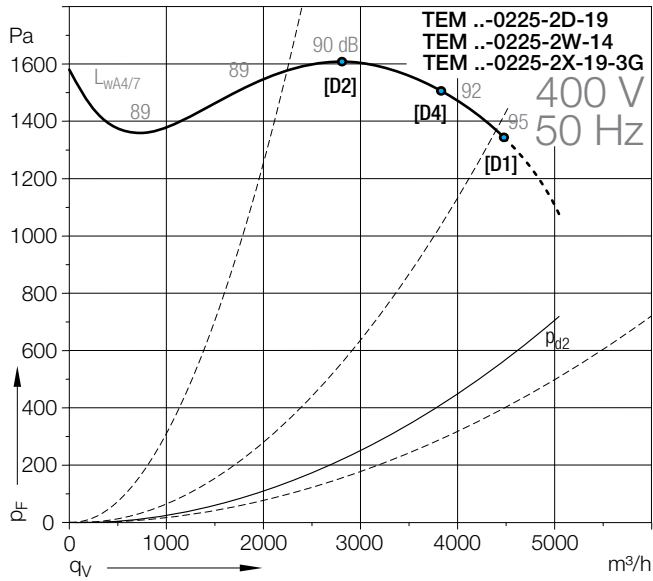
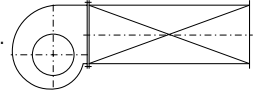

# TEM 01-0225

# TEM 08-0225

## Technical Data

TEM ...	Curves	Nominal motor power kW	Poles	Motor size	Motor voltage V	Nominal frequency Hz	Connection	Nominal motor current A	Nominal motor speed 1/min	Max. media Temperature °C	Max. volume flow m³/h	Weight TEM 01/08 kg
0225-2W-19	[D1]	4.00	2	112 M	400	50	△	7.80	2950	60	4500	41/46
0225-2W-14	[D2]	2.20	2	90 L	230/400	50	△/Y	7.80/4.50	2890	60	2800	21/30
0225-4W-11	[D3]	0.75	4	80 M	230/400	50	△/Y	3.01/1.74	1440	60	2640	14/19

Ex II 3G c IIB T3 TEM ...	Curves	Nominal motor power kW	Poles	Motor size	Motor voltage V	Nominal frequency Hz	Connection	Nominal motor current A	Nominal motor speed 1/min	Max. media Temperature °C	Max. volume flow m³/h	Weight TEM 01/08 kg
0225-2X-19-3G	[D4]	3.30	2	112 M	230/400	50	△/Y	11.60/6.70	2875	60	3870	43/48
0225-4X-11-3G	[D5]	0.75	4	80	230/400	50	△/Y	3.55/2.05	1395	60	2640	14/19

60 Hz TEM ...	Curves	Nominal motor power kW	Poles	Motor size	Motor voltage V	Nominal frequency Hz	Connection	Nominal motor current A	Nominal motor speed 1/min	Max. media Temperature °C	Max. volume flow m³/h	Weight TEM 01/08 kg
0225-2W-19-60	[D6]	4.60	2	112 M	460	60	△	7.70	3550	60	4020	41/46
0225-2W-14-60	[D7]	2.55	2	90 L	460	60	Y	4.50	3468	60	2330	30/35
0225-4W-11-60	[D8]	0.86	4	80 M	460	60	Y	1.79	1728	60	2780	14/19

The given nominal motor current may not be exceeded. If the current consumption is exceeded, the volume is to be throttled correspondingly.  
 For fans of the ATEX execution, the guarantee for operation in explosion endangered areas or for the conveyance of explosive atmosphere expires when the motor nominal current is exceeded! For information on fans of the ATEX execution see Technical Description of this chapter.

Motor protection can take place through motor protection units with bi-metallic releases (EUM 33) or via a thermistor (NTC) temperature sensor in connection with a thermistor (NTC)-release device (EUM 03). See chapter "Accessories".  
 The direction of rotation is determined looking from the drive side. Anti-clockwise rotation, symbol **LG**. Clockwise rotation, symbol **RD**.

### Dimensions in mm, subject to change.

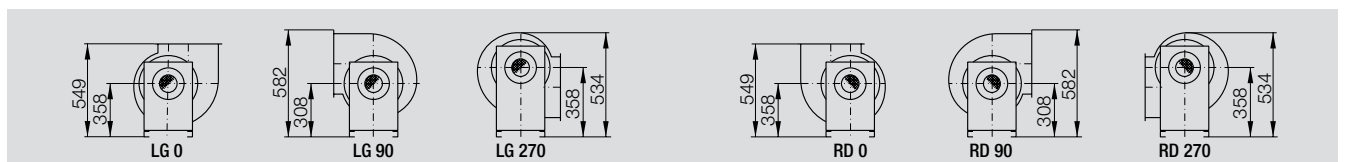
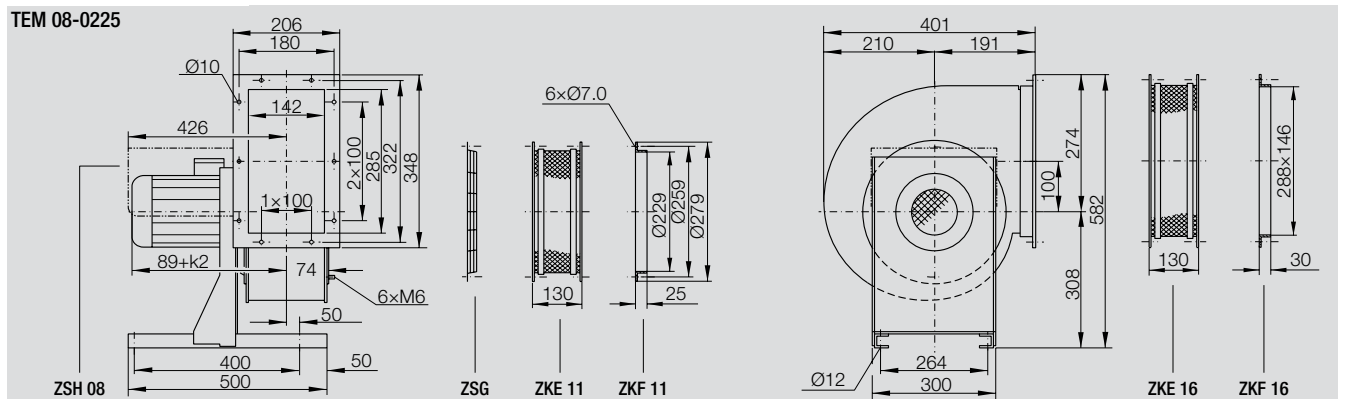
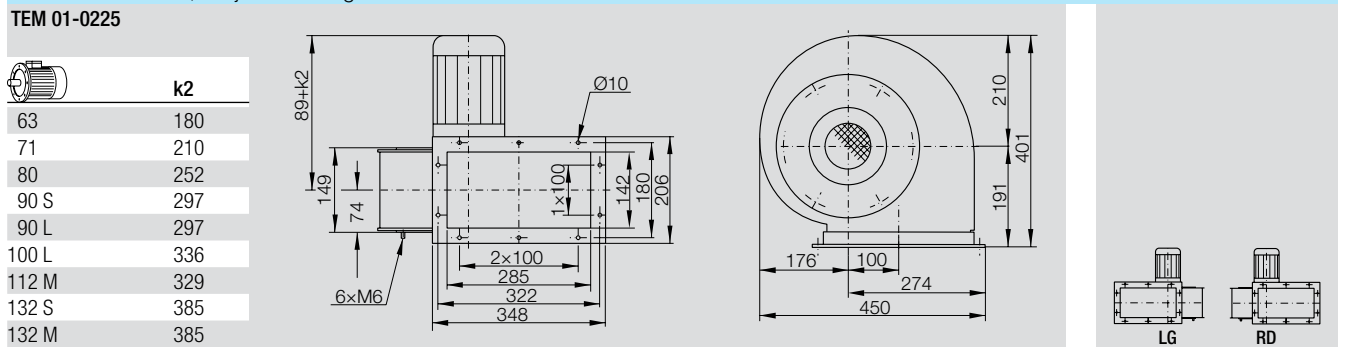

# TEM 01-0250

# TEM 08-0250

### Curves

- Operation limit, see Technical Data
- do not use in this area!

Density of media **1.2 kg/m<sup>3</sup>**.

Measured in installation **B** according to **ISO 5801** (ducted).

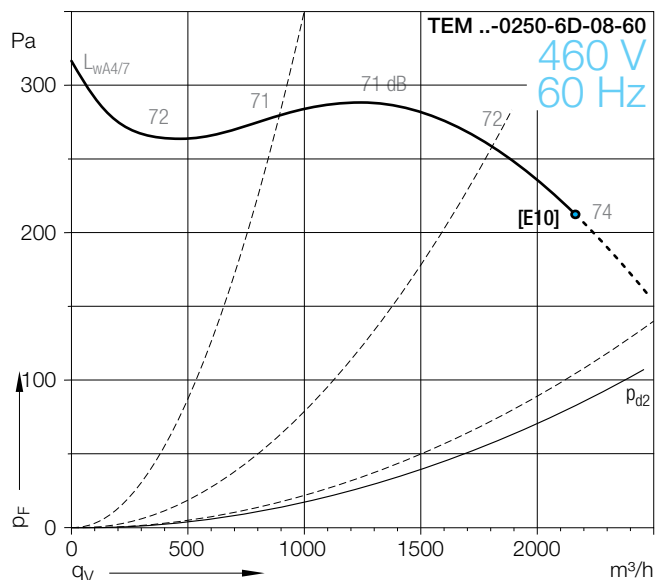
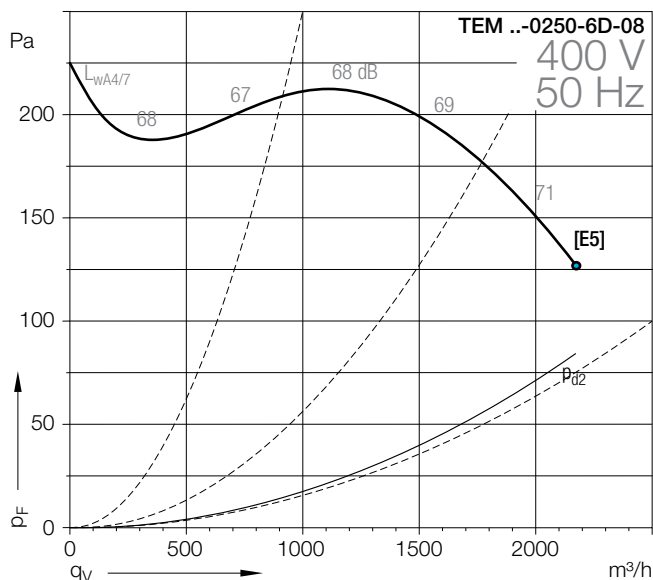
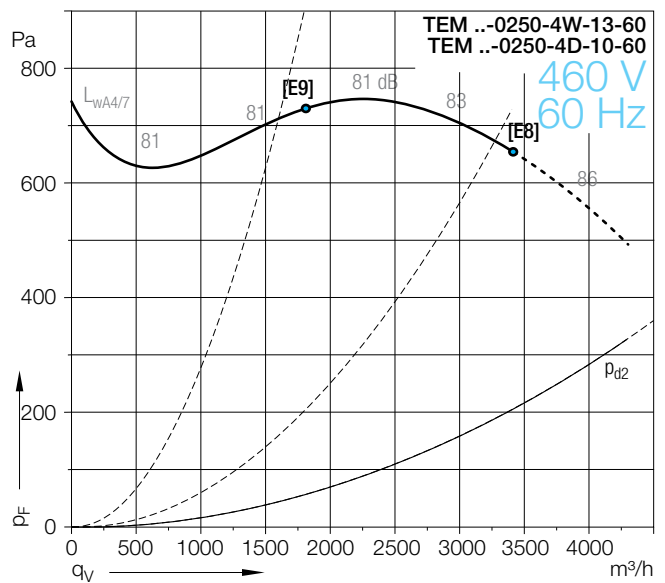
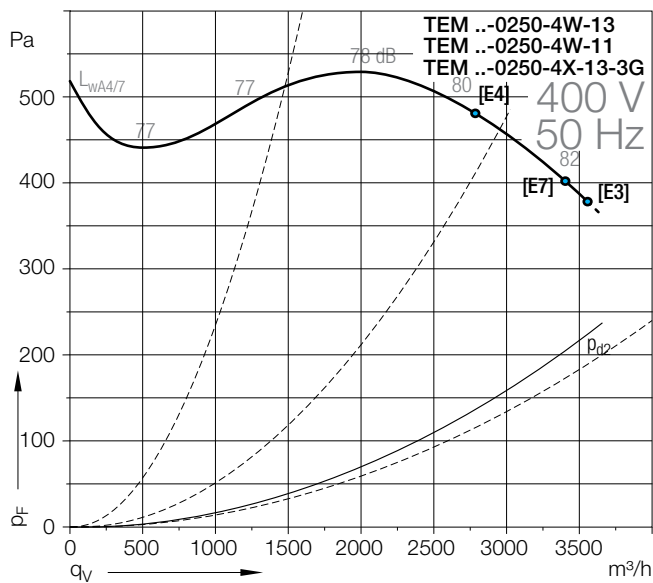
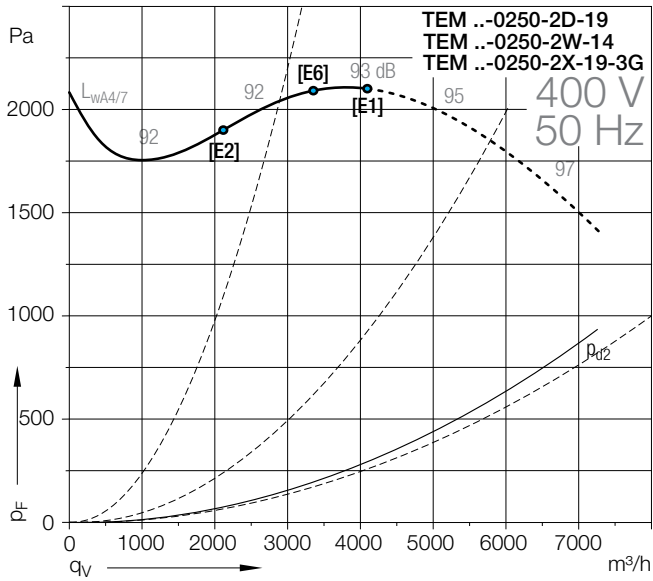
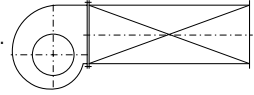



# TEM 01-0250

# TEM 08-0250

## Technical Data

TEM ...	Curves	Nominal motor power kW	Poles	Motor size	Motor voltage V	Nominal frequency Hz	Connection	Nominal motor current A	Nominal motor speed 1/min	Max. media Temperature °C	Max. volume flow m³/h	Weight TEM 01/08 kg
0250-2W-19	[E1]	4.00	2	112 M	400	50	△	7.80	2950	60	4100	42/48
0250-2W-14	[E2]	2.20	2	90 L	230/400	50	△/Y	7.80/4.50	2890	60	2180	31/37
0250-4W-13	[E3]	1.10	4	90 S	230/400	50	△/Y	4.30/2.50	1425	60	3600	17/23
0250-4W-11	[E4]	0.75	4	80 M	230/400	50	△/Y	3.10/1.79	1440	60	2790	15/21
0250-6D-08	[E5]	0.25	6	71	230/400	50	△/Y	1.35/0.78	830	60	2190	12/18

Ex II 3G c IIB T3 TEM ...	Curves	Nominal motor power kW	Poles	Motor size	Motor voltage V	Nominal frequency Hz	Connection	Nominal motor current A	Nominal motor speed 1/min	Max. media Temperature °C	Max. volume flow m³/h	Weight TEM 01/08 kg
0250-2X-19-3G	[E6]	3.30	2	112 M	230/400	50	△/Y	11.60/6.70	2875	60	3340	44/50
0250-4X-13-3G	[E7]	1.00	4	90S	230/400	50	△/Y	4.30/2.50	1420	60	3390	17/23

60 Hz TEM ...	Curves	Nominal motor power kW	Poles	Motor size	Motor voltage V	Nominal frequency Hz	Connection	Nominal motor current A	Nominal motor speed 1/min	Max. media Temperature °C	Max. volume flow m³/h	Weight TEM 01/08 kg
0250-4W-13-60	[E8]	1.27	4	90 S	460	60	Y	2.50	1710	60	3430	17/23
0250-4D-10-60	[E9]	0.63	4	80	460	60	Y	1.45	1674	60	1800	13/19
0250-6D-08-60	[E10]	0.29	6	71	460	60	Y	0.76	1060	60	2180	12/18

The given nominal motor current may not be exceeded. If the current consumption is exceeded, the volume is to be throttled correspondingly.  
 For fans of the ATEX execution, the guarantee for operation in explosion endangered areas or for the conveyance of explosive atmosphere expires when the motor nominal current is exceeded! For information on fans of the ATEX execution see Technical Description of this chapter.

Motor protection can take place through motor protection units with bi-metallic releases (EUM 33) or via a thermistor (NTC) temperature sensor in connection with a thermistor (NTC)-release device (EUM 03). See chapter "Accessories".  
 The direction of rotation is determined looking from the drive side.  
 Anti-clockwise rotation, symbol **LG**. Clockwise rotation, symbol **RD**.

### Dimensions in mm, subject to change.

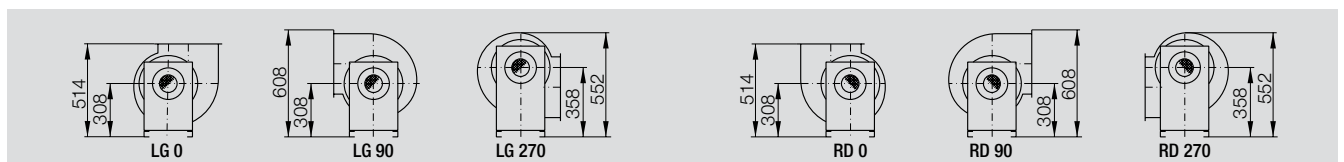
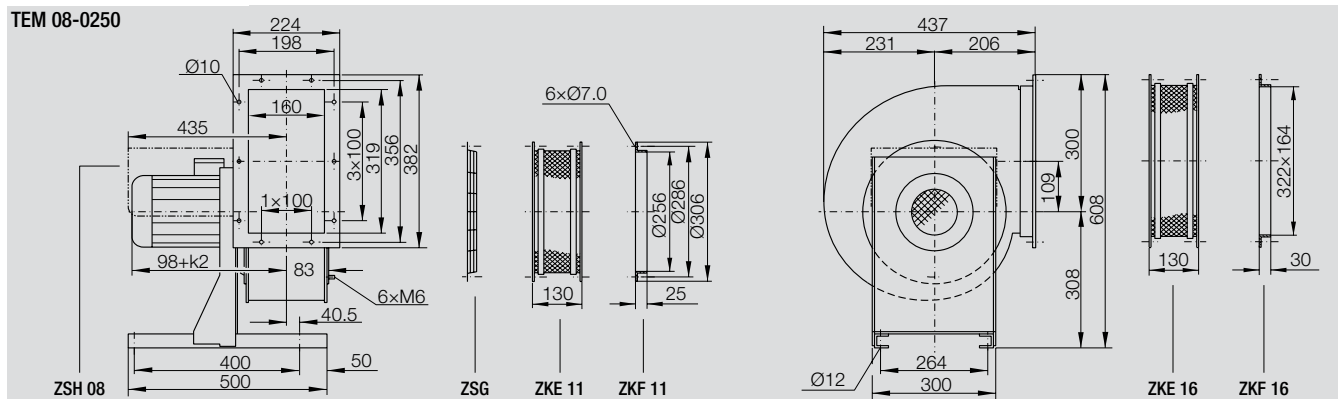
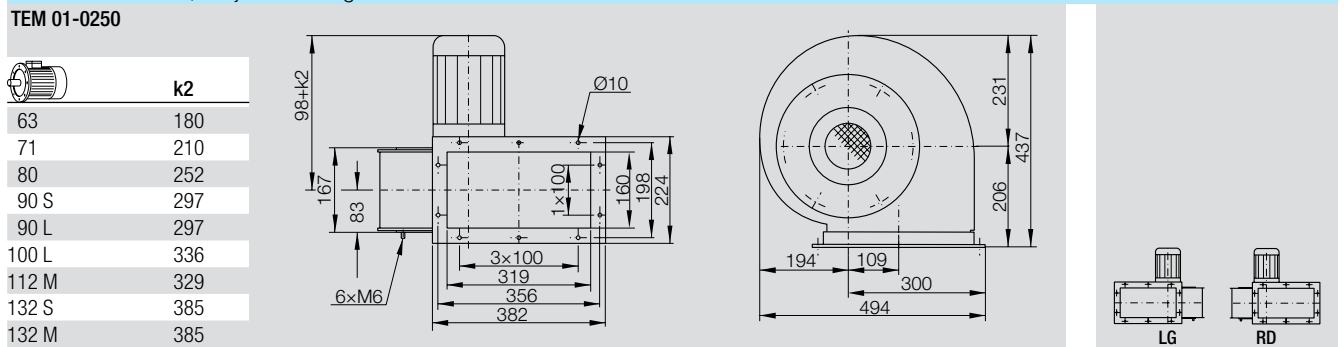

# TEM 01-0280

# TEM 08-0280

### Curves

- Operation limit, see Technical Data
- do not use in this area!

Density of media **1.2 kg/m<sup>3</sup>**.

Measured in installation **B** according to **ISO 5801** (ducted).

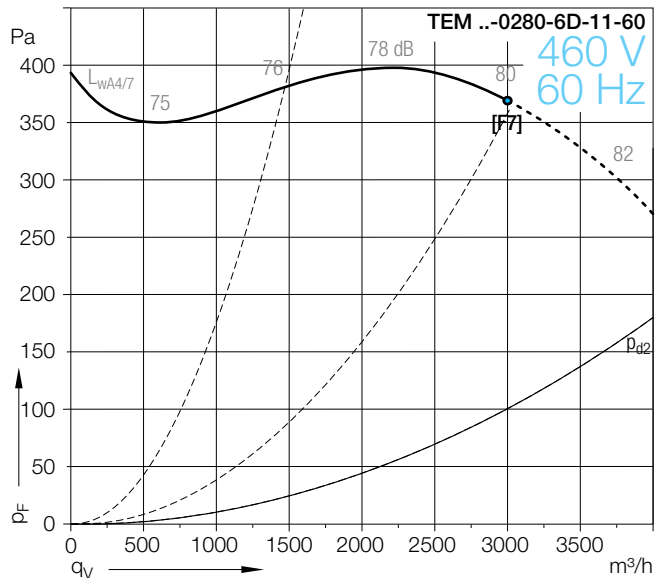
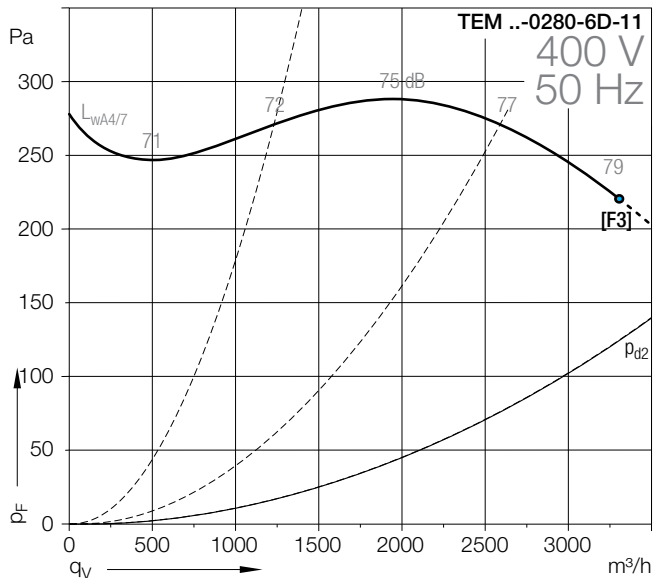
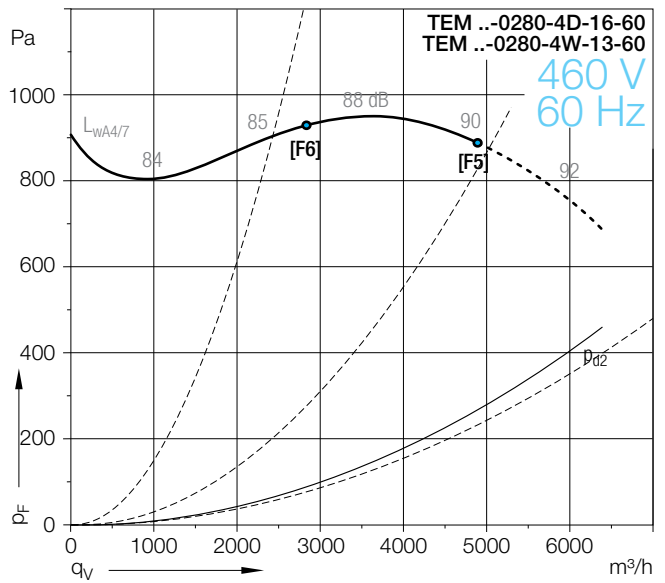
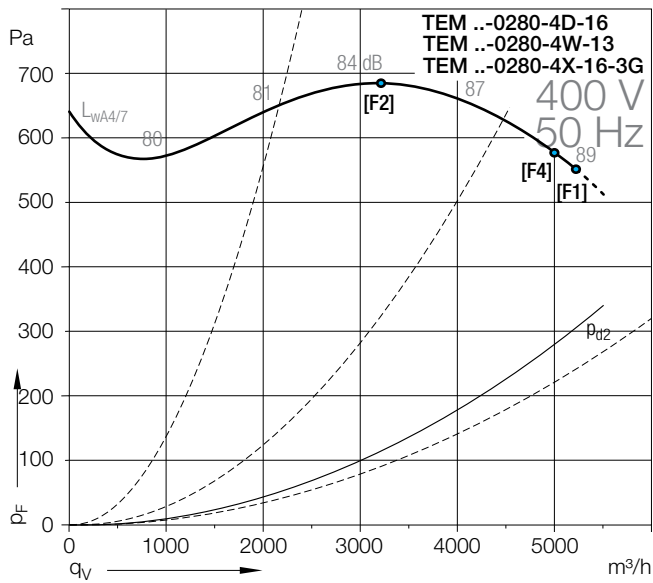
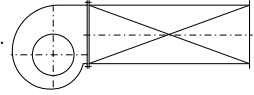

# TEM 01-0280 TEM 08-0280

Technical Data												
TEM ..-	Curves	Nominal motor power kW	Poles	Motor size	Motor voltage V	Nominal frequency Hz	Connection	Nominal motor current A	Nominal motor speed 1/min	Max. media Temperature °C	Max. volume flow m³/h	Weight TEM 01/08 kg
0280-4W-16	[F1]	2.20	4	100 L	230/400	50	Δ/Y	8.05/4.65	1455	60	5250	28/36
0280-4W-13	[F2]	1.10	4	90 S	230/400	50	Δ/Y	4.30/2.50	1425	60	3200	18/26
0280-6D-11	[F3]	0.55	6	80	230/400	50	Δ/Y	2.80/1.60	910	60	3300	16/24

Ex II 3G c IIB T3												
TEM ..-	Curves	Nominal motor power kW	Poles	Motor size	Motor voltage V	Nominal frequency Hz	Connection	Nominal motor current A	Nominal motor speed 1/min	Max. media Temperature °C	Max. volume flow m³/h	Weight TEM 01/08 kg
0280-4X-16-3G	[F4]	2.00	4	100 L	230/400	50	Δ/Y	7.80/4.50	1420	60	5000	35/44

  

60 Hz												
TEM ..-	Curves	Nominal motor power kW	Poles	Motor size	Motor voltage V	Nominal frequency Hz	Connection	Nominal motor current A	Nominal motor speed 1/min	Max. media Temperature °C	Max. volume flow m³/h	Weight TEM 01/08 kg
0280-4W-16-60	[F5]	2.55	4	100 L	460	60	Y	4.50	1755	60	4920	28/33
0280-4W-13-60	[F6]	1.27	4	90 S	460	60	Y	2.50	1710	60	2760	18/26
0280-6D-11-60	[F7]	0.63	6	80	460	60	Y	1.55	1110	60	3030	16/24

The given nominal motor current may not be exceeded. If the current consumption is exceeded, the volume is to be throttled correspondingly.  
 For fans of the ATEX execution, the guarantee for operation in explosion endangered areas or for the conveyance of explosive atmosphere expires when the motor nominal current is exceeded! For information on fans of the ATEX execution see Technical Description of this chapter.

Motor protection can take place through motor protection units with bi-metallic releases (EUM 33) or via a thermistor (NTC) temperature sensor in connection with a thermistor (NTC)-release device (EUM 03). See chapter "Accessories".  
 The direction of rotation is determined looking from the drive side. Anti-clockwise rotation, symbol **LG**. Clockwise rotation, symbol **RD**.

**Dimensions** in mm, subject to change.

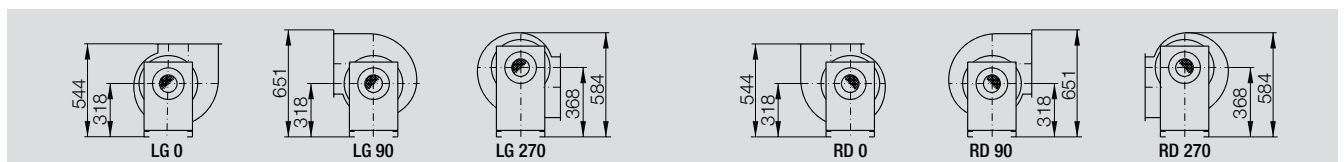
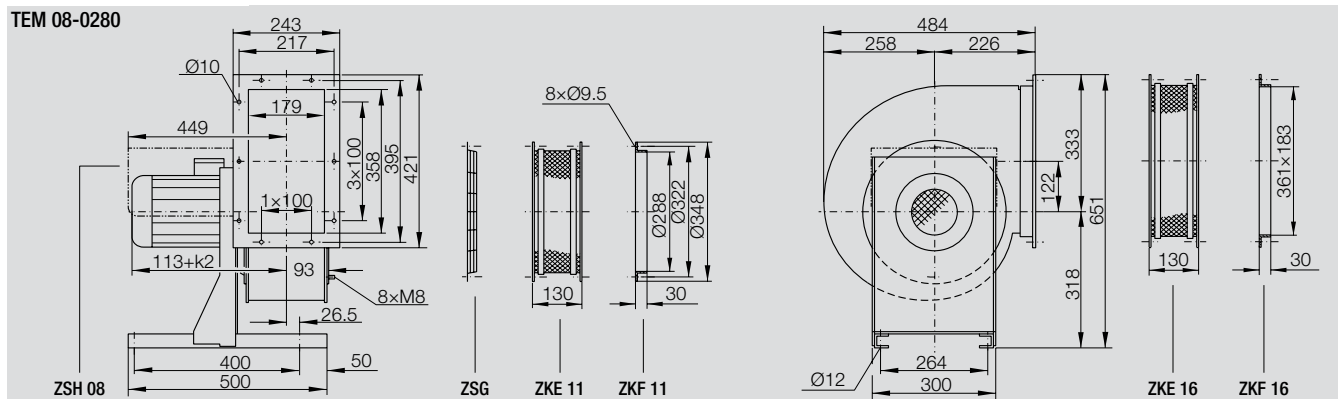
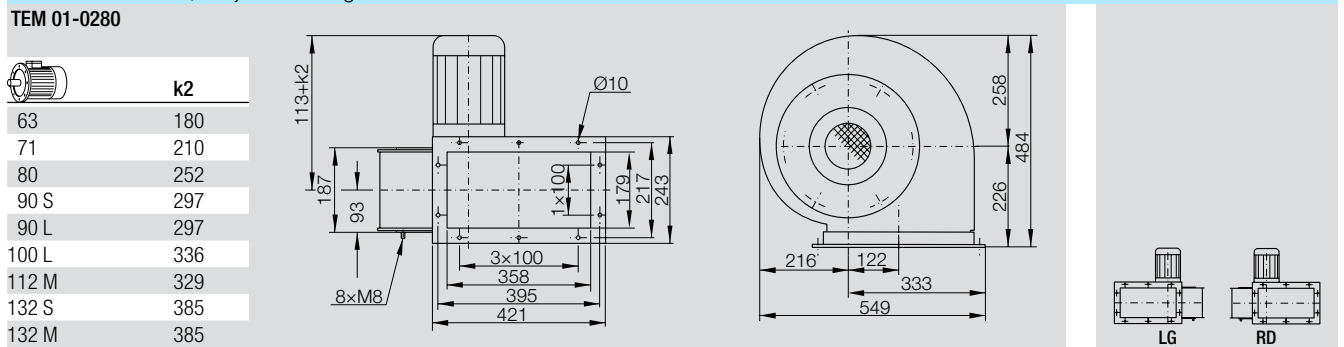

# TEM 01-0315

# TEM 08-0315

### Curves

- Operation limit, see Technical Data
- do not use in this area!

Density of media **1.2 kg/m<sup>3</sup>**.

Measured in installation **B** according to **ISO 5801** (ducted).

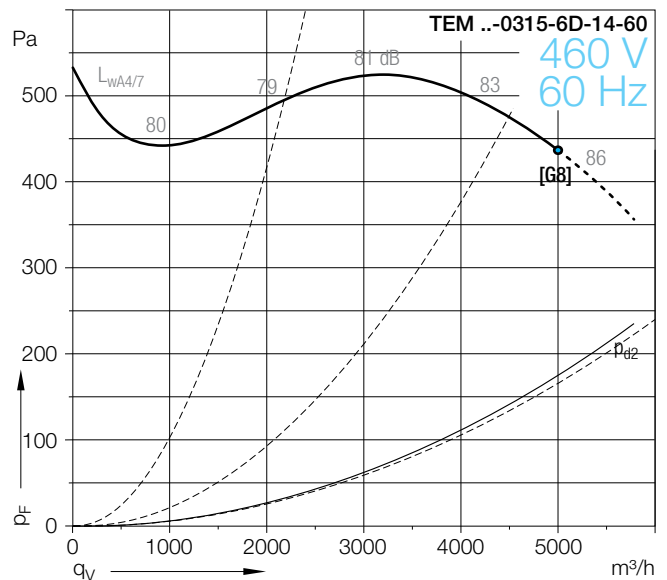
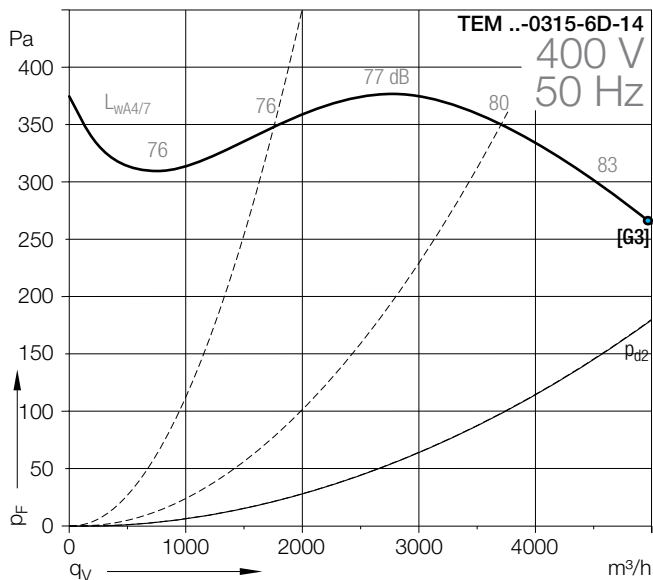
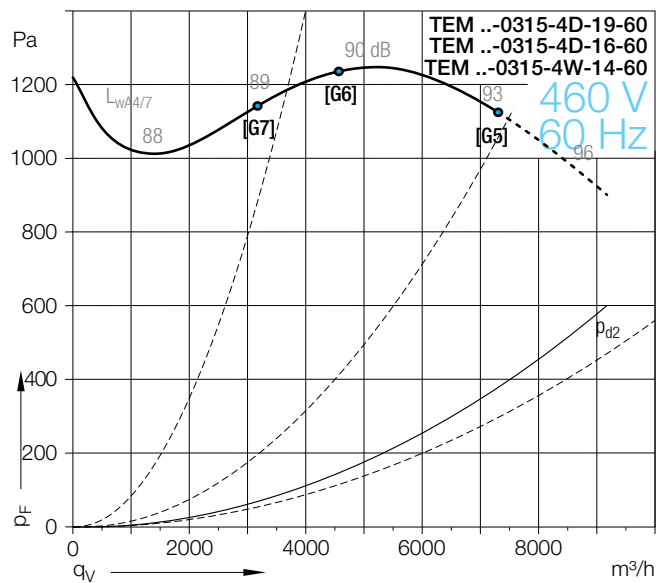
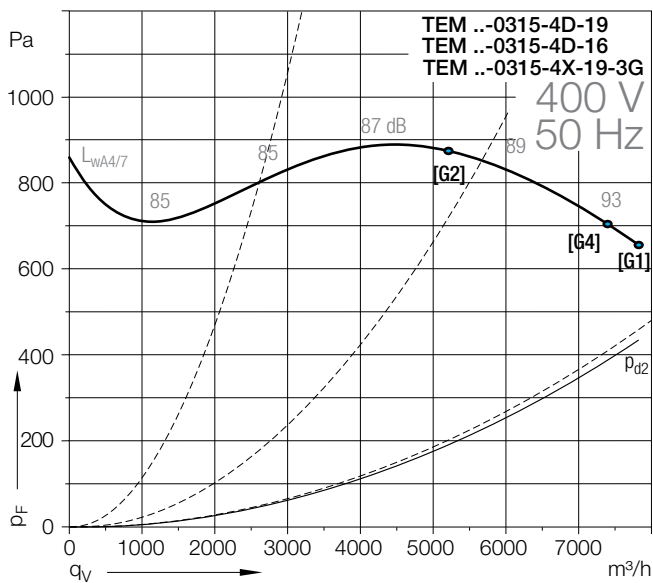
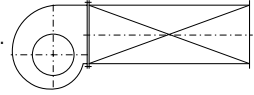

# TEM 01-0315

# TEM 08-0315

Technical Data												
TEM ..-	Curves	Nominal motor power kW	Poles	Motor size	Motor voltage V	Nominal frequency Hz	Connection	Nominal motor current A	Nominal motor speed 1/min	Max. media Temperature °C	Max. volume flow m³/h	Weight TEM 01/08 kg
0315-4W-19	[G1]	4.00	4	112 M	400 D	50	△	8.20	1460	60	7830	47/54
0315-4W-16	[G2]	2.20	4	100 L	230/400	50	△/Y	8.05/4.65	1455	60	5200	29/40
0315-6W-14	[G3]	1.10	6	90 L	230/400	50	△/Y	5.00/2.90	940	60	4980	26/37

Ex II 3G c IIB T3												
TEM ..-	Curves	Nominal motor power kW	Poles	Motor size	Motor voltage V	Nominal frequency Hz	Connection	Nominal motor current A	Nominal motor speed 1/min	Max. media Temperature °C	Max. volume flow m³/h	Weight TEM 01/08 kg
0315-4X-19-3G	[G4]	3.60	4	112 M	230/400	50	△/Y	13.00/7.50	1435	60	7400	49/60

  

60 Hz												
TEM ..-	Curves	Nominal motor power kW	Poles	Motor size	Motor voltage V	Nominal frequency Hz	Connection	Nominal motor current A	Nominal motor speed 1/min	Max. media Temperature °C	Max. volume flow m³/h	Weight TEM 01/08 kg
0315-4W-19-60	[G5]	4.55	4	112 M	460	60	△	8.00	1760	60	7400	47/54
0315-4W-16-60	[G6]	2.55	4	100 L	460	60	Y	4.50	1755	60	4550	40/47
0315-4W-14-60	[G7]	1.75	4	90 L	460	60	Y	3.30	1722	60	3130	33/40
0315-6W-14-60	[G8]	1.30	6	90 L	460	60	Y	3.05	1140	60	5000	26/37

The given nominal motor current may not be exceeded. If the current consumption is exceeded, the volume is to be throttled correspondingly.  
 For fans of the ATEX execution, the guarantee for operation in explosion endangered areas or for the conveyance of explosive atmosphere expires when the motor nominal current is exceeded! For information on fans of the ATEX execution see Technical Description of this chapter.

Motor protection can take place through motor protection units with bi-metallic releases (EUM 33) or via a thermistor (NTC) temperature sensor in connection with a thermistor (NTC)-release device (EUM 03). See chapter "Accessories".  
 The direction of rotation is determined looking from the drive side. Anti-clockwise rotation, symbol **LG**. Clockwise rotation, symbol **RD**.

**Dimensions** in mm, subject to change.

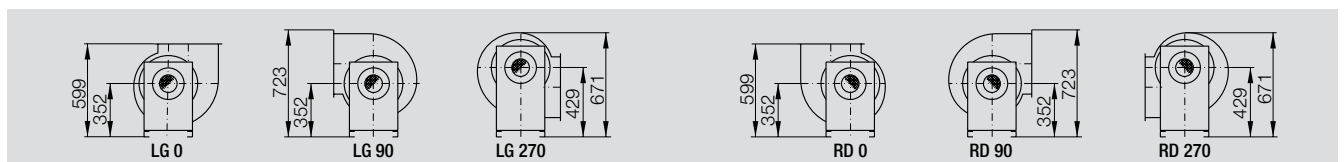
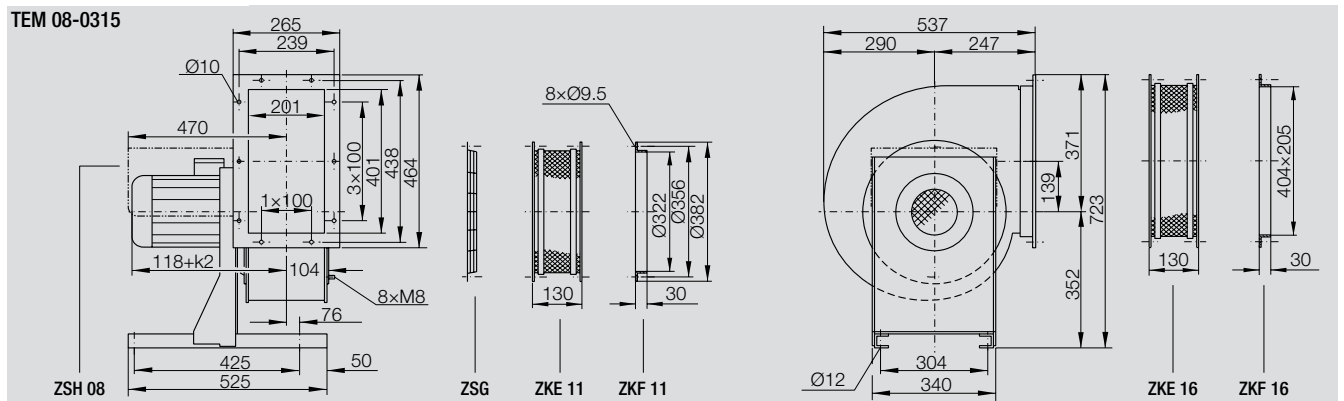
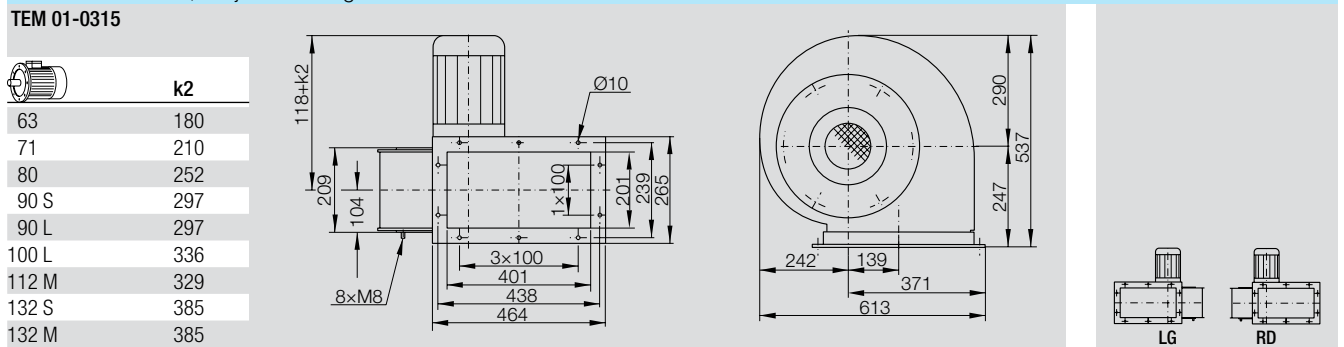

# TEM 01-0355

# TEM 08-0355

### Curves

- Operation limit, see Technical Data
- do not use in this area!

Density of media **1.2 kg/m<sup>3</sup>**.

Measured in installation **B** according to **ISO 5801** (ducted).

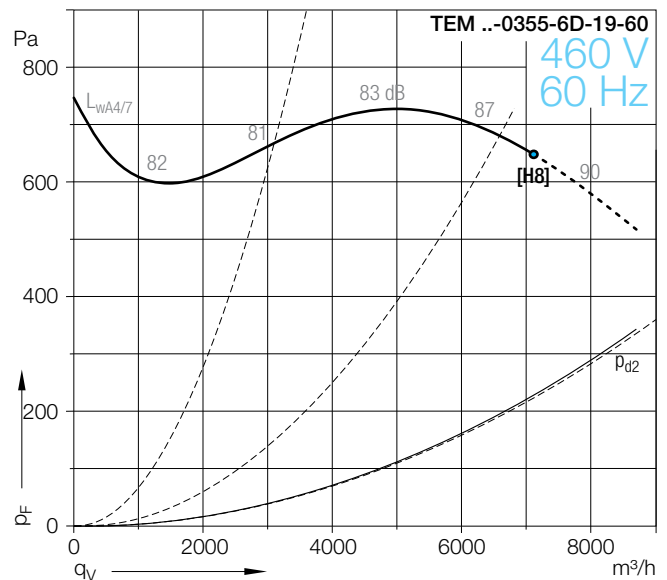
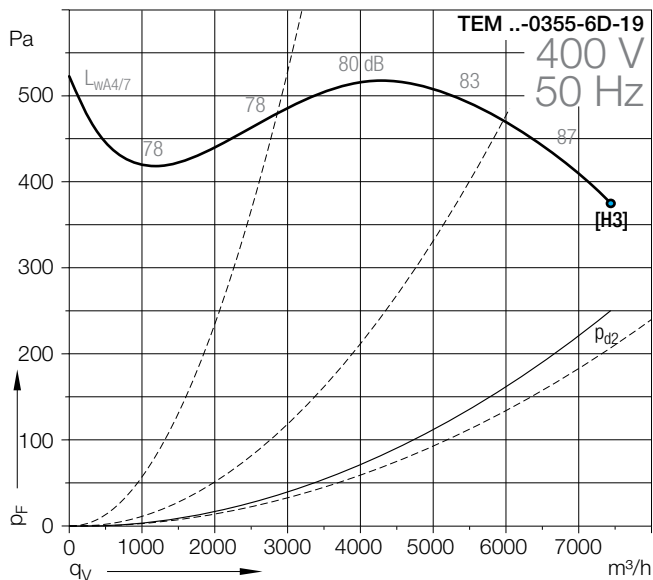
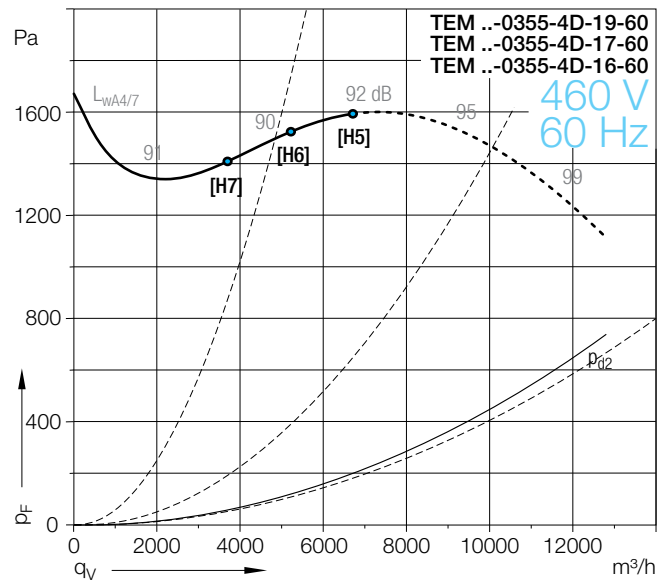
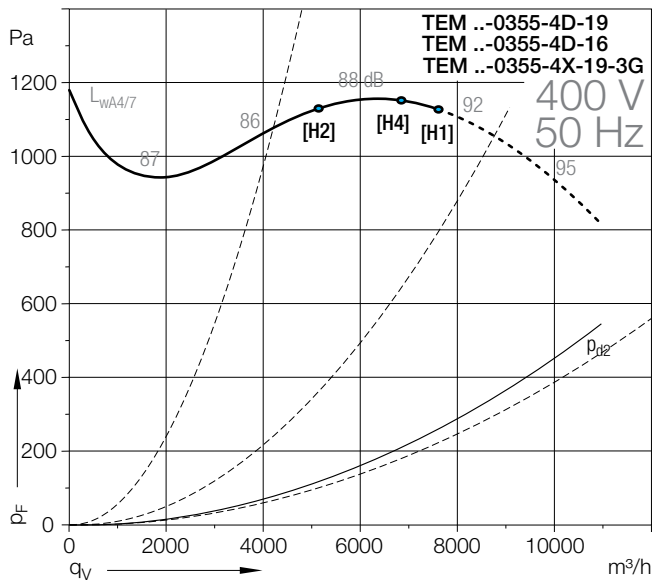
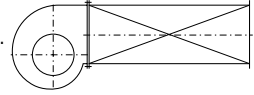



# TEM 01-0355

# TEM 08-0355

Technical Data												
TEM ..-	Curves	Nominal motor power kW	Poles	Motor size	Motor voltage V	Nominal frequency Hz	Connection	Nominal motor current A	Nominal motor speed 1/min	Max. media Temperature °C	Max. volume flow m³/h	Weight TEM 01/08 kg
0355-4W-19	[H1]	4.00	4	112 M	400	50	△	8.20	1460	60	7600	48/57
0355-4W-16	[H2]	2.20	4	100 L	230/400	50	△/Y	8.05/4.65	1455	60	4600	41/50
0355-6W-19	[H3]	2.20	6	112 M	230/400	50	△/Y	9.00/5.20	965	60	7450	46/59

Ex II 3G c IIB T3												
TEM ..-	Curves	Nominal motor power kW	Poles	Motor size	Motor voltage V	Nominal frequency Hz	Connection	Nominal motor current A	Nominal motor speed 1/min	Max. media Temperature °C	Max. volume flow m³/h	Weight TEM 01/08 kg
0355-4X-19-3G	[H4]	3.60	4	112 M	230/400	50	△/Y	13.00/7.50	1435	60	6900	50/63

  

60 Hz												
TEM ..-	Curves	Nominal motor power kW	Poles	Motor size	Motor voltage V	Nominal frequency Hz	Connection	Nominal motor current A	Nominal motor speed 1/min	Max. media Temperature °C	Max. volume flow m³/h	Weight TEM 01/08 kg
0355-4W-19-60	[H5]	4.55	4	112 M	460	60	△	8.00	1760	60	6680	48/57
0355-4W-17-60	[H6]	3.45	4	100 L	460	60	Y	6.00	1755	60	5150	45/54
0355-4W-16-60	[H7]	2.55	4	100 L	460	60	Y	4.50	1755	60	3780	41/50
0355-6W-19-60	[H8]	2.55	6	112 M	460	60	Y	4.80	1165	60	7170	46/59

The given nominal motor current may not be exceeded. If the current consumption is exceeded, the volume is to be throttled correspondingly.  
 For fans of the ATEX execution, the guarantee for operation in explosion endangered areas or for the conveyance of explosive atmosphere expires when the motor nominal current is exceeded! For information on fans of the ATEX execution see Technical Description of this chapter.

Motor protection can take place through motor protection units with bi-metallic releases (EUM 33) or via a thermistor (NTC) temperature sensor in connection with a thermistor (NTC)-release device (EUM 03). See chapter "Accessories".  
 The direction of rotation is determined looking from the drive side. Anti-clockwise rotation, symbol **LG**. Clockwise rotation, symbol **RD**.

**Dimensions** in mm, subject to change.

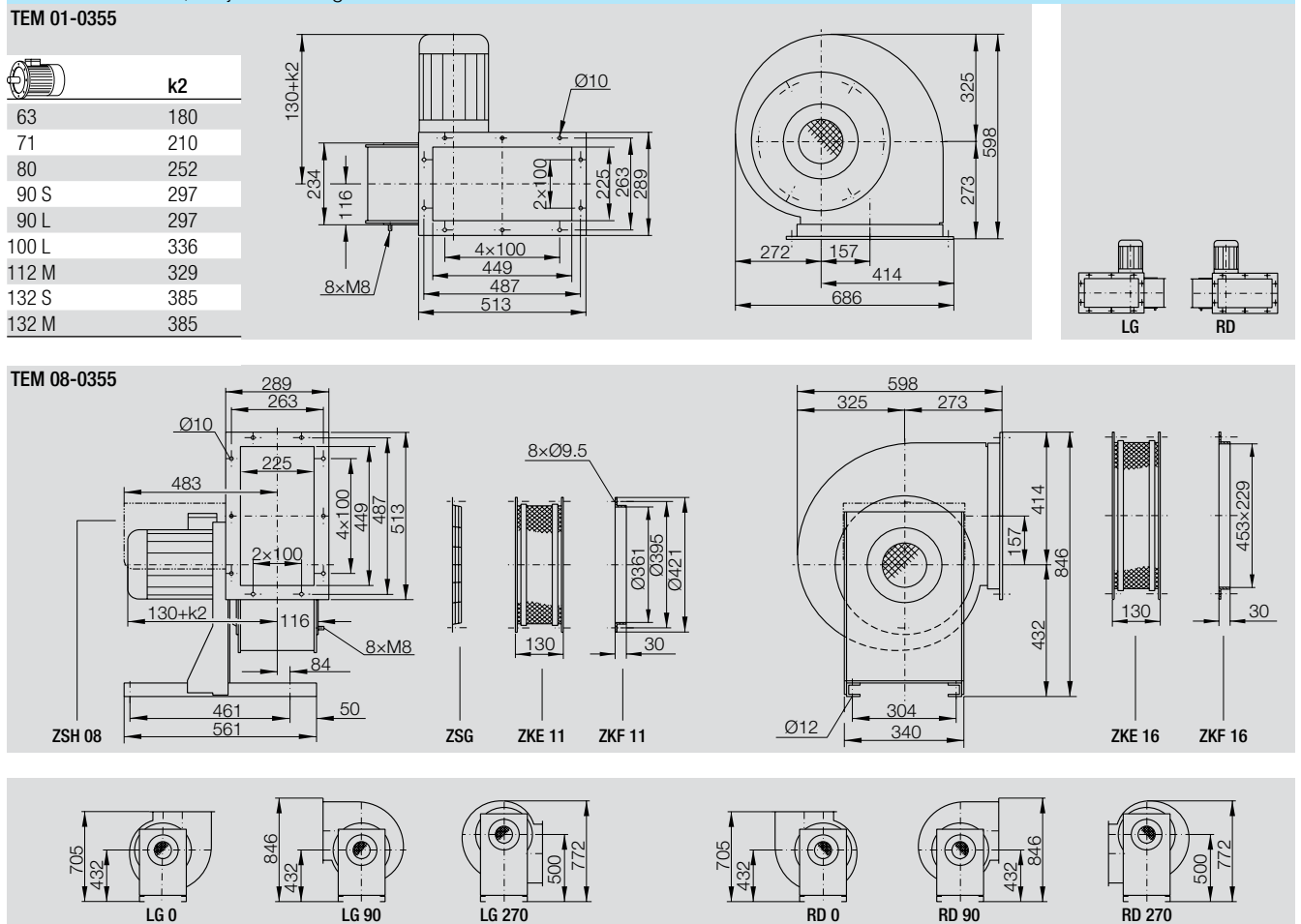

# Technical Data

## Technical Data according to ErP-REGULATION 327/2011/EU

50 Hz TEM ..-	Overall efficiency $\eta_e$ [%]	Measure- ment category	Efficiency category	achieved	required		Speed control (VSD)	Rated motor	Flow rate	Pressure	Speed	"specific ratio"
				efficiency grade at optimum energy efficiency "N"	efficiency grade acc. to ErP since 2013	2015		power at optimum energy efficiency $P_e$ [kW]	at optimum energy efficiency $q_v$ [m <sup>3</sup> /h]	at optimum energy efficiency $p_F$ [Pa]	at optimum energy efficiency N [1/min]	
0160-2D-08	35.0	B	TOTAL	43.2	42	49	without	0.501	880	717	2900	1.007
0180-2W-11	43.6	B	TOTAL	50.5	42	49	without	0.823	1270	1018	2930	1.010
0200-2W-14	45.6	B	TOTAL	51.2	42	49	without	1.315	1750	1233	2960	1.012
0225-2W-19	49.3	B	TOTAL	53.4	42	49	without	2.258	2500	1603	2970	1.016
0225-2W-14	48.6	B	TOTAL	52.6	42	49	without	2.293	2500	1603	2970	1.016
0250-2W-19	51.0	B	TOTAL	53.3	42	49	without	4.301	3730	2116	2930	1.021
0250-2W-14	46.3	B	TOTAL	50.1	42	49	without	2.511	2180	1920	2970	1.019
0180-4D-05	26.3	B	TOTAL	37.6	42	49	without	0.163	630	245	1440	1.002
0200-4D-08	29.1	B	TOTAL	39.2	42	49	without	0.246	860	299	1460	1.003
0225-4W-11	39.8	B	TOTAL	49.1	42	49	without	0.340	1240	393	1470	1.004
0250-4W-13	45.1	B	TOTAL	52.8	42	49	without	0.609	1870	529	1465	1.005
0250-4W-11	46.8	B	TOTAL	54.6	42	49	without	0.587	1870	529	1465	1.005
0280-4W-16	44.0	B	TOTAL	50.0	42	49	without	1.129	2650	675	1480	1.007
0280-4W-13	45.1	B	TOTAL	51.1	42	49	without	1.103	2650	675	1480	1.007
0315-4W-19	50.6	B	TOTAL	55.3	42	49	without	1.831	3800	878	1480	1.009
0315-4W-16	52.0	B	TOTAL	56.8	42	49	without	1.781	3800	878	1480	1.009
0355-4W-19	56.2	B	TOTAL	59.4	42	49	without	3.047	5400	1141	1470	1.011
0355-4W-16	54.0	B	TOTAL	57.7	42	49	without	2.610	4600	1103	1470	1.011
0250-6D-08	32.5	B	TOTAL	43.1	42	49	without	0.217	1200	212	930	1.002
0280-6D-11	33.7	B	TOTAL	42.5	42	49	without	0.406	1720	286	960	1.003
0315-6W-14	42.4	B	TOTAL	50.1	42	49	without	0.612	2500	374	970	1.004
0355-6W-19	48.1	B	TOTAL	54.3	42	49	without	1.039	3550	507	980	1.005

# Technical Data

## Technical Data according to ErP-REGULATION 327/2011/EU

60 Hz TEM ...-	Overall efficiency $\eta_e$ [%]	Measure- ment category	Efficiency category	achieved efficiency grade at optimum energy efficiency "N"	required efficiency grade acc. to ErP since		Speed control (VSD)	Rated motor power at optimum energy efficiency $P_e$ [kW]	Flow rate at optimum energy efficiency $q_v$ [m³/h]	Pressure at optimum energy efficiency $p_F$ [Pa]	Speed at optimum energy efficiency $N$ [1/min]	"specific ratio"
					2013	2015						
0160-2D-08-60	35.9	B	TOTAL	42.9	42	49	without	0.779	1030	978	3390	1.010
0180-2W-11-60	45.2	B	TOTAL	50.8	42	49	without	1.296	1500	1407	3440	1.014
0180-2W-10-60	40.0	B	TOTAL	46.0	42	49	without	1.111	1180	1356	3480	1.014
0200-2W-14-60	47.3	B	TOTAL	51.5	42	49	without	2.130	2100	1726	3500	1.017
0200-2W-11-60	45.8	B	TOTAL	51.1	42	49	without	1.498	1510	1637	3530	1.016
0225-2W-19-60	50.0	B	TOTAL	52.8	42	49	without	3.691	2950	2254	3520	1.023
0225-2W-14-60	47.5	B	TOTAL	50.8	42	49	without	2.982	2330	2187	3540	1.022
0160-4D-05-60	22.7	B	TOTAL	34.0	42	49	without	0.167	530	258	1740	1.003
0180-4D-05-60	29.3	B	TOTAL	39.5	42	49	without	0.242	750	340	1690	1.003
0200-4D-08-60	33.8	B	TOTAL	42.9	42	49	without	0.362	1050	420	1720	1.004
0225-4W-11-60	43.7	B	TOTAL	51.9	42	49	without	0.513	1460	553	1740	1.006
0250-4W-13-60	49.4	B	TOTAL	55.9	42	49	without	0.923	2200	746	1740	1.007
0250-4D-10-60	40.2	B	TOTAL	46.8	42	49	without	0.906	1800	729	1750	1.007
0280-4W-16-60	48.0	B	TOTAL	52.9	42	49	without	1.690	3100	942	1750	1.009
0280-4W-13-60	45.9	B	TOTAL	51.0	42	49	without	1.548	2760	926	1750	1.009
0315-4W-19-60	53.9	B	TOTAL	57.2	42	49	without	2.940	4600	1239	1760	1.012
0315-4W-16-60	53.6	B	TOTAL	57.0	42	49	without	2.914	4550	1237	1760	1.012
0315-4W-14-60	47.5	B	TOTAL	51.9	42	49	without	2.083	3130	1139	1770	1.011
0355-4W-19-60	56.6	B	TOTAL	58.5	42	49	without	4.906	6300	1586	1730	1.016
0355-4W-17-60	55.3	B	TOTAL	57.9	42	49	without	3.943	5150	1524	1750	1.015
0355-4W-16-60	51.1	B	TOTAL	54.5	42	49	without	2.914	3780	1418	1760	1.014
0250-6D-08-60	34.6	B	TOTAL	44.1	42	49	without	0.316	1370	287	1080	1.003
0280-6D-11-60	36.2	B	TOTAL	43.8	42	49	without	0.625	2050	397	1130	1.004
0315-6W-14-60	45.7	B	TOTAL	52.2	42	49	without	0.940	2950	524	1150	1.005
0355-6W-19-60	56.0	B	TOTAL	61.2	42	49	without	1.490	4200	715	1160	1.007

# TEM 01-0160/-0355

## Specifications



### High performance centrifugal fan TEM 01

single inlet, direct driven.

Lap-jointed scroll housing made from galvanised steel sheet, without pedestal for vertical or horizontal mounting.

Suitable for conveying medium temperatures from -20 °C to +60 °C.

At discharge with integrated flange acc. to DIN 24159-3, at intake with possibility to connect with flange acc. to DIN 24155-2.

Galvanised impeller with forward curved blades. B5 motor mounted outside the airstream.

Impeller balanced in according to DIN ISO 1940, completely maintenance free.

Motor equipped with PTC Thermistors as a standard (except motors in explosion proof execution according to ATEX 94/9/EC).

Three phase 400 V, 50 Hz, single speed.

## Fan data

Fan type	TEM 01	
Volume flow	$q_V$	m <sup>3</sup> /h
Total pressure increase	$p_F$	Pa
Air density at fan inlet	$\rho_1$	kg/m <sup>3</sup>
Air temperature	$t$	°C
Speed	$N$	1/min
Nominal motor power	$P_N$	kW
Voltage	$U$	V
Frequency	$f$	Hz
Sound power level (A weighted)	$L_{WA}$	dB
Weight	$m$	kg

## Fittings / Accessories

- ▶ Drain plug R1/2"
- ▶ Inspection door
- ▶ Corrosion protection S40
  
- ▶ Inlet flange
- ▶ Inlet flex (with flexible sleeve)
- ▶ Discharge flange
- ▶ Discharge flex (with flexible sleeve)
- ▶ Inlet protection guard
- ▶ Discharge protection guard
  
- ▶ Isolator
- ▶ Motor protection unit

# TEM 08-0160/-0355

## Specifications



### High performance centrifugal fan TEM 08

single inlet, direct driven.

Lap-jointed scroll housing made from galvanised steel sheet, with pedestal for horizontal mounting.

Suitable for conveying medium temperatures from -20 °C to +60 °C.

At discharge with integrated flange acc. to DIN 24159-3, at intake with possibility to connect with flange acc. to DIN 24155-2.

Galvanised impeller with forward curved blades. B5 motor mounted outside the airstream.

Impeller balanced in according to DIN ISO 1940, completely maintenance free.

Motor equipped with PTC Thermistors as a standard (except motors in explosion proof execution according to ATEX 94/9/EC).

Three phase 400 V, 50 Hz, single speed.

## Fan data

Fan type	TEM 08		
Volume flow	$q_V$		m <sup>3</sup> /h
Total pressure increase	$p_F$		Pa
Air density at fan inlet	$\rho_1$		kg/m <sup>3</sup>
Air temperature	t		°C
Speed	N		1/min
Nominal motor power	$P_N$		kW
Voltage	U		V
Frequency	f		Hz
Sound power level (A weighted)	$L_{WA}$		dB
Weight	m		kg

## Fittings / Accessories

- ▶ Drain plug R1/2"
- ▶ Inspection door
- ▶ Corrosion protection S40
  
- ▶ Inlet flange
- ▶ Inlet flex (with flexible sleeve)
- ▶ Discharge flange
- ▶ Discharge flex (with flexible sleeve)
- ▶ Inlet protection guard
- ▶ Discharge protection guard
- ▶ Anti-vibration mounts
  
- ▶ Isolator
- ▶ Motor protection unit

# Powerful centrifugal fans for universal use

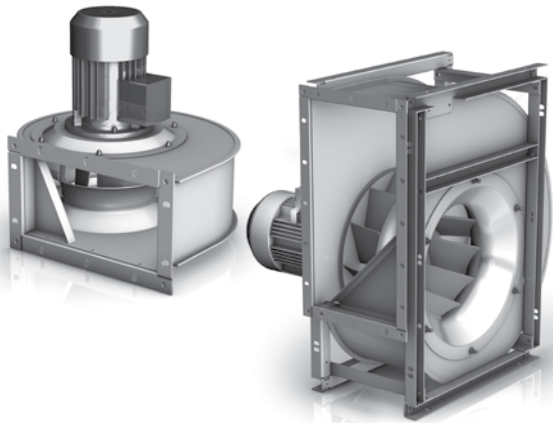

## The product ranges REM

The fan ranges REM offered by Nicotra Gebhardt do present a large fan programme of single inlet centrifugal fans which are universally usable for many ventilation purposes either in HVAC or in machinery design industry and heavy duty installation business.

The fans are available with with impellers equipped with backward curved blades. The fans are equipped with IEC flanged (B5) standard motors, protection IP55, class F, and they are suitable for frequency inverter controlled operation.

### Benefits:

- ▶ compact design because of direct drive
- ▶ cost effective by maintenance-free operation
- ▶ speed controlled by frequency inverter
- ▶ universally usable due to different options, such as
- ▶ without brackets as a directly fitted unit for operation with vertical shaft arrangement
- ▶ with brackets for operation with horizontal shaft
- ▶ ATEX execution for explosion hazardous areas and applications  
Ex II 2G c IIB T3







# The universal technology for various applications

## REM ranges

- ▶ Sizes from 0200 up to 0630
- ▶ Volume flow up to 20,000m³/h
- ▶ also in available 60Hz execution
- ▶ also available in ATEX execution 2G
- ▶ motor with PTC in flange execution
- ▶ Impeller with backward curved blades

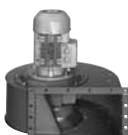
For applications in the filter technologie, drying- and suction plants.

For every application, the suitable fan:

Version	Description	Figure
<b>REM 11-0200/-0630</b>	Lap jointed scroll of galvanised sheet steel with discharge flange and built-in impeller with backward curved aerofoil blades, without pedestal, for vertical or horizontal mounting.	
<b>REM 18-0200/-0630</b>	Lap jointed scroll of galvanised sheet steel with discharge flange and built-in impeller with backward curved aerofoil blades, with pedestal, for horizontal mounting.	
<b>REM 13-0200/-0630</b>	Scroll casing stitch welded with discharge flange, epoxy coated, built-in impeller with backward curved aerofoil blades, without pedestal, for vertical or horizontal mounting.	
<b>REM 19-0200/-0630</b>	Scroll casing stitch welded with discharge flange, epoxy coated, built-in impeller with backward curved aerofoil blades, with pedestal, for horizontal mounting.	
<b>REM 41-0200/-0450</b>	Lap jointed scroll of galvanised sheet steel with discharge flange and built-in impeller with backward curved blades, without pedestal, for vertical or horizontal mounting.	
<b>REM 48-0200/-0450</b>	Lap jointed scroll of galvanised sheet steel with discharge flange and built-in impeller with backward curved blades, with pedestal, for horizontal mounting.	

**REM 11-0200**  
**REM 13-0200**

**REM 18-0200**  
**REM 19-0200**

**Curves**

Density of media **1.2 kg/m<sup>3</sup>**.  
Measured in installation **B** according to **ISO 5801** (ducted).

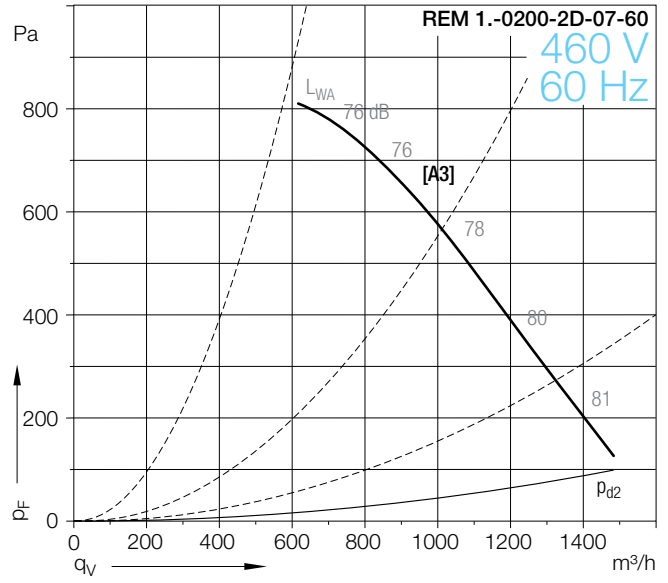
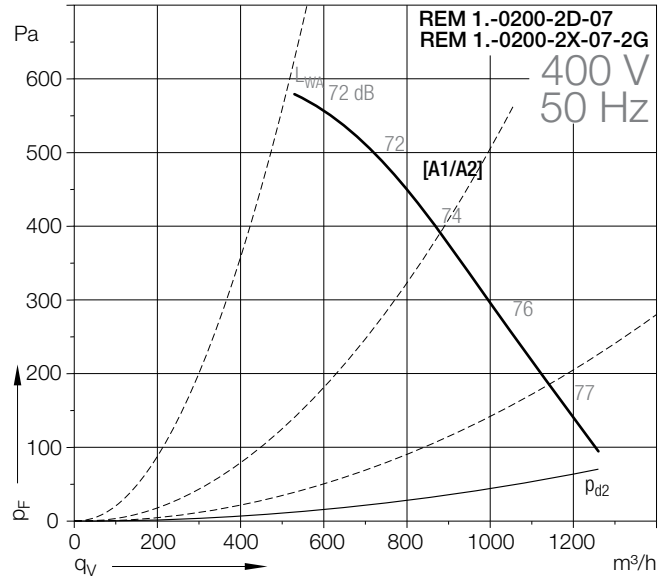
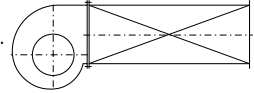



# REM 11-0200 REM 13-0200

# REM 18-0200 REM 19-0200

Technical Data												
REM	Curves	Nominal motor power kW	Poles	Motor size	Motor voltage V	Nominal frequency Hz	Connection	Nominal motor current A	Nominal motor speed 1/min	Max. media Temperature °C	Max. volume flow m³/h	Weight REM 11/13/18/19 kg
11-/13-/18-/19-0200-2D-07	[A1]	0.37	2	71	230/400	50	Δ/Y	1.73/1.00	2740	60	1290	10/12/14/16
Ex II 3G c IIB T3												
REM	Curves	Nominal motor power kW	Poles	Motor size	Motor voltage V	Nominal frequency Hz	Connection	Nominal motor current A	Nominal motor speed 1/min	Max. media Temperature °C	Max. volume flow m³/h	Weight REM 11/13/18/19 kg
11-/13-/18-/19-0200-2X-07-2G	[A2]	0.37	2	71	230/400	50	Δ/Y	1.61/0.93	2825	60	1290	10/12/14/16
60 Hz												
REM	Curves	Nominal motor power kW	Poles	Motor size	Motor voltage V	Nominal frequency Hz	Connection	Nominal motor current A	Nominal motor speed 1/min	Max. media Temperature °C	Max. volume flow m³/h	Weight REM 11/13/18/19 kg
11-/13-/18-/19-0200-2D-07-60	[A3]	0.43	2	71	460	60	Y	1.00	3288	60	1520	10/12/14/16

Motor protection can take place through motor protection units with bi-metallic releases (EUM 33) or via a thermistor (NTC) temperature sensor in connection with a thermistor (NTC)-release device (EUM 03). See chapter "Accessories".

The direction of rotation is determined looking from the drive side. Anti-clockwise rotation, symbol **LG**. Clockwise rotation, symbol **RD**.

**Dimensions** in mm, subject to change.

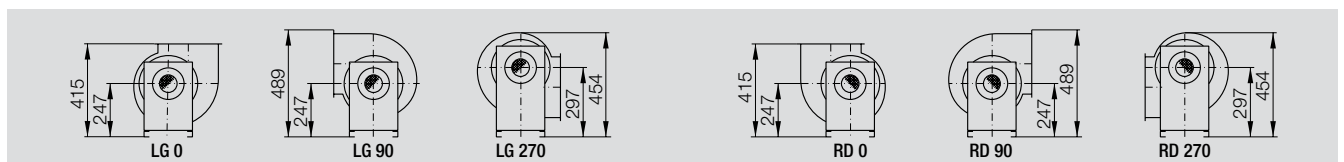
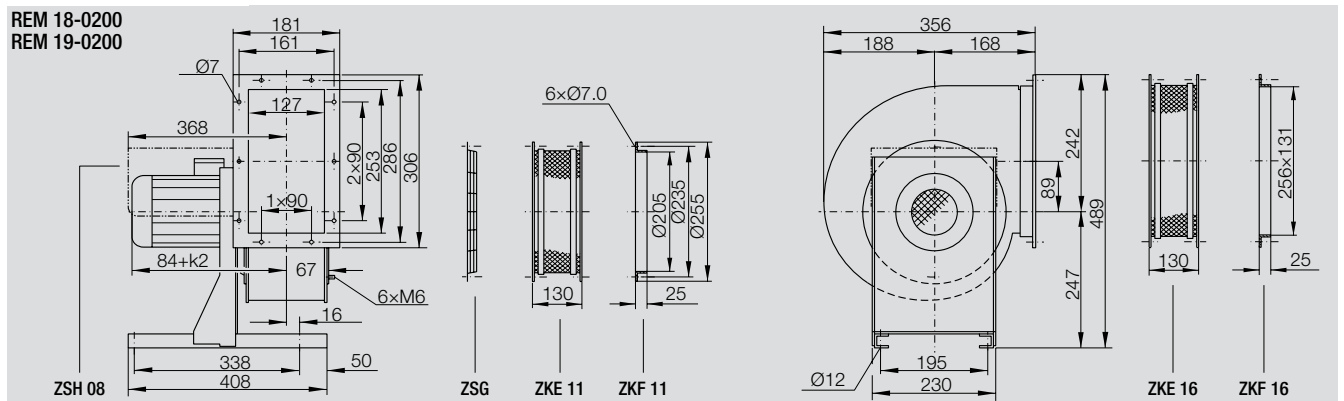
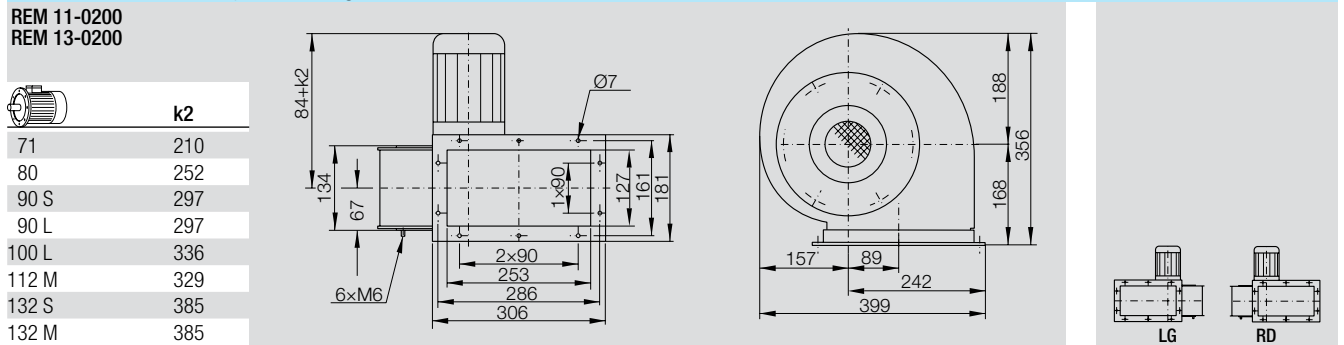

**REM 11-0225**  
**REM 13-0225**

**REM 18-0225**  
**REM 19-0225**

**Curves**

Density of media **1.2 kg/m<sup>3</sup>**.  
Measured in installation **B** according to **ISO 5801** (ducted).

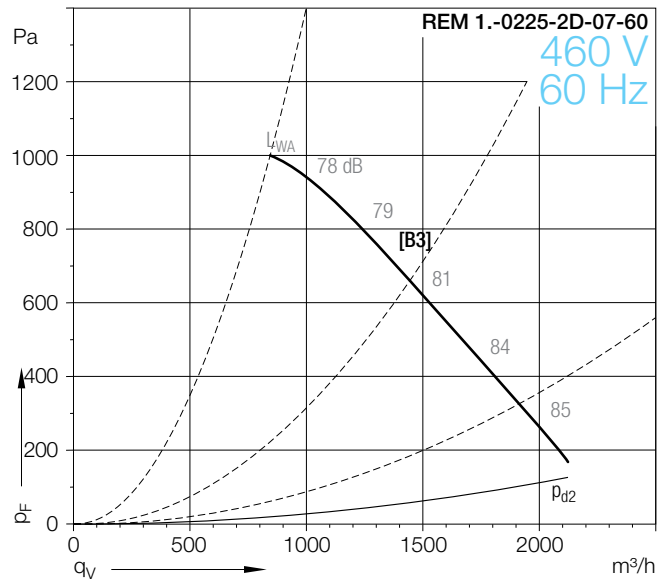
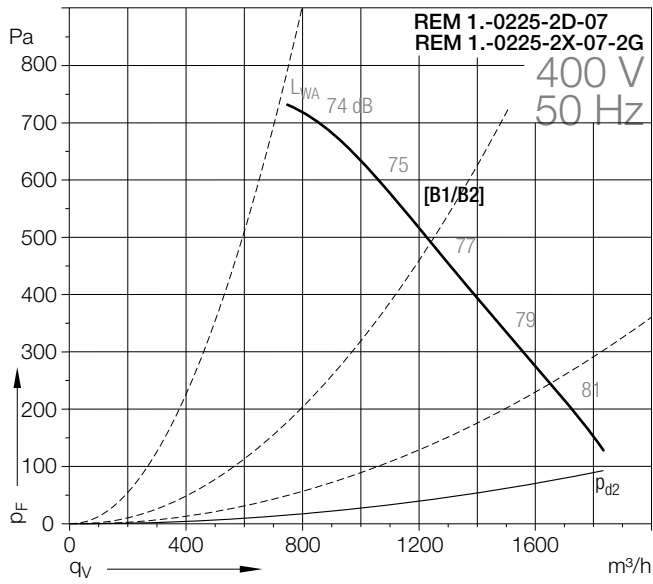
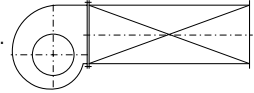

**REM 11-0225**  
**REM 13-0225**

**REM 18-0225**  
**REM 19-0225**

Technical Data												
REM	Curves	Nominal motor power kW	Poles	Motor size	Motor voltage V	Nominal frequency Hz	Connection	Nominal motor current A	Nominal motor speed 1/min	Max. media Temperature °C	Max. volume flow m³/h	Weight REM 11/13/18/19 kg
11-/13-/18-/19-0225-2D-07	[B1]	0.37	2	71	230/400	50	Δ/Y	1.73/1.00	2740	60	1880	11/13/16/18
Ex II 3G c IIB T3												
REM	Curves	Nominal motor power kW	Poles	Motor size	Motor voltage V	Nominal frequency Hz	Connection	Nominal motor current A	Nominal motor speed 1/min	Max. media Temperature °C	Max. volume flow m³/h	Weight REM 11/13/18/19 kg
11-/13-/18-/19-0225-2X-07-2G	[B2]	0.37	2	71	230/400	50	Δ/Y	1.61/0.93	2825	60	1880	11/13/16/18
60 Hz												
REM	Curves	Nominal motor power kW	Poles	Motor size	Motor voltage V	Nominal frequency Hz	Connection	Nominal motor current A	Nominal motor speed 1/min	Max. media Temperature °C	Max. volume flow m³/h	Weight REM 11/13/18/19 kg
11-/13-/18-/19-0225-2D-07-60	[B3]	0.43	2	71	460	60	Y	1.00	3288	60	2170	11/13/16/18

Motor protection can take place through motor protection units with bi-metallic releases (EUM 33) or via a thermistor (NTC) temperature sensor in connection with a thermistor (NTC)-release device (EUM 03). See chapter "Accessories".

The direction of rotation is determined looking from the drive side. Anti-clockwise rotation, symbol **LG**. Clockwise rotation, symbol **RD**.

**Dimensions** in mm, subject to change.

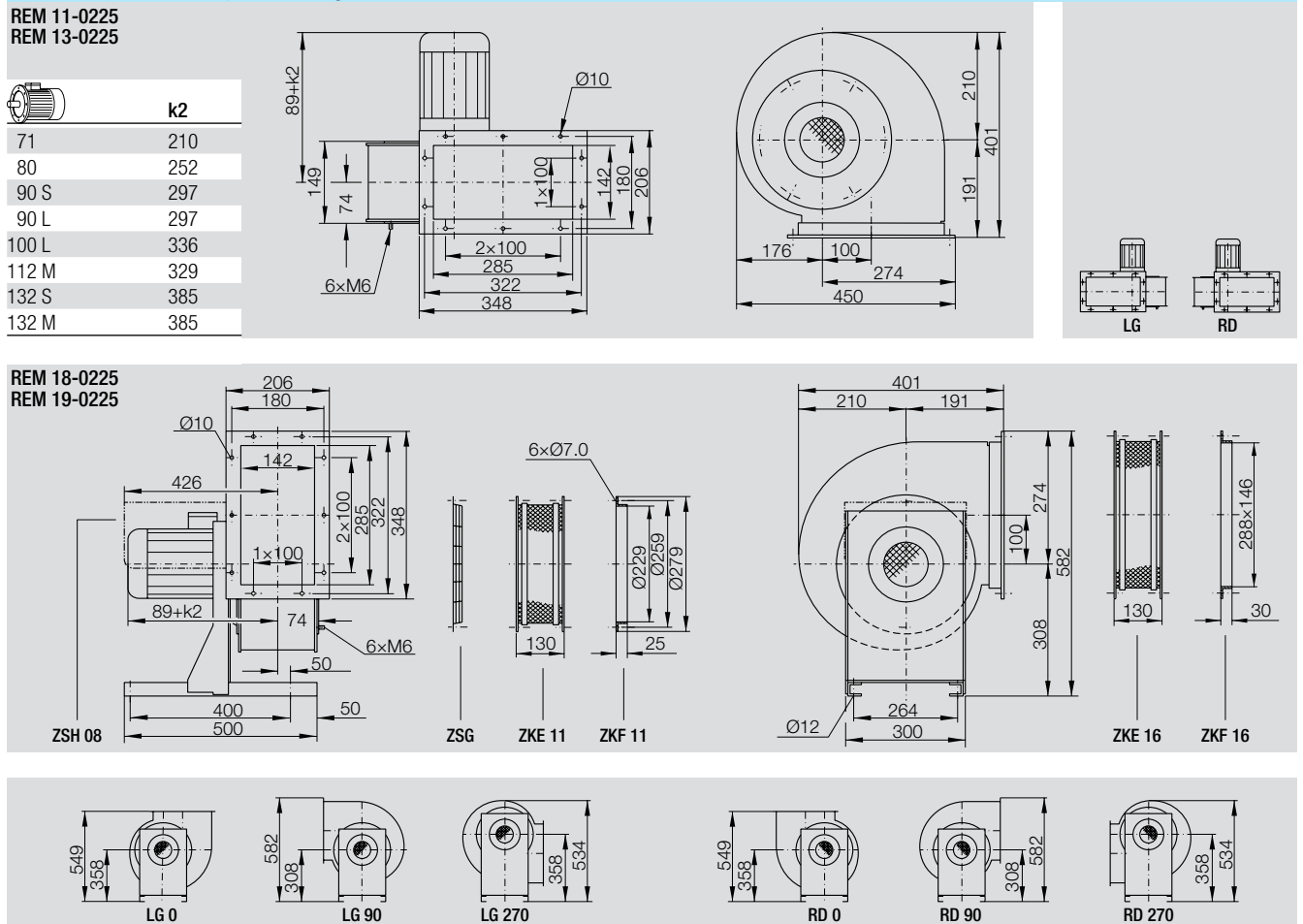

**REM 11-0250**  
**REM 13-0250**

**REM 18-0250**  
**REM 19-0250**

**Curves**

Density of media **1.2 kg/m<sup>3</sup>**.  
Measured in installation **B** according to **ISO 5801** (ducted).

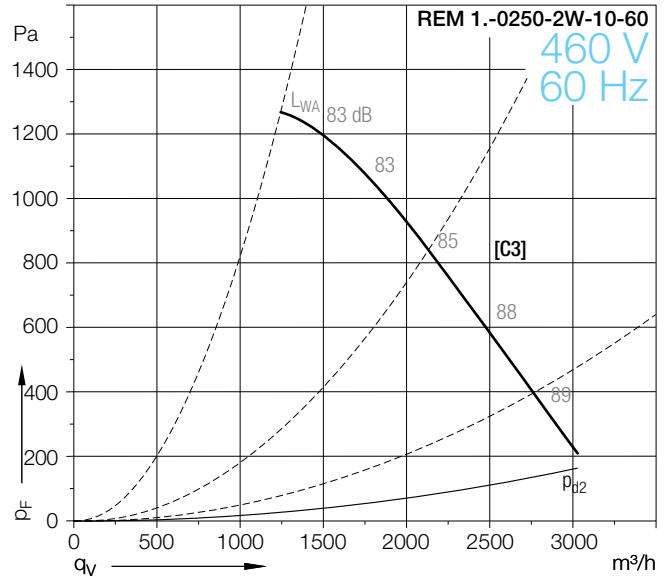
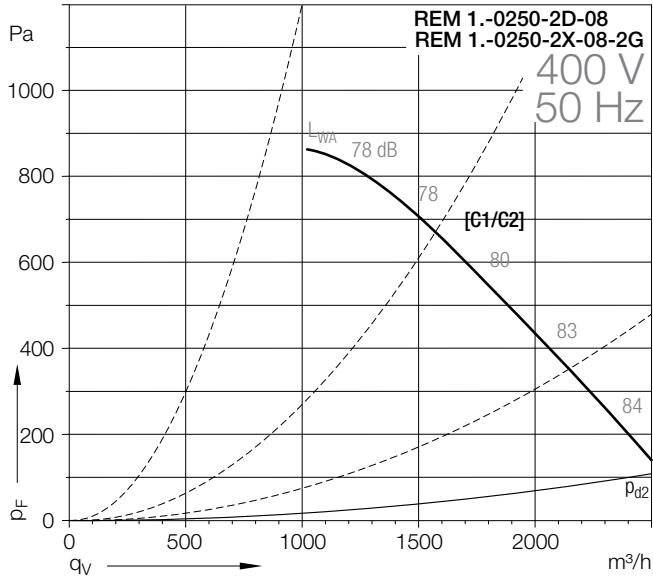
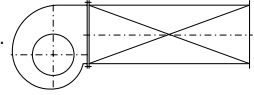

# REM 11-0250 REM 13-0250

# REM 18-0250 REM 19-0250

Technical Data												
REM	Curves	Nominal motor power kW	Poles	Motor size	Motor voltage V	Nominal frequency Hz	Connection	Nominal motor current A	Nominal motor speed 1/min	Max. media Temperature °C	Max. volume flow m³/h	Weight REM 11/13/18/19 kg
11-/13-/18-/19-0250-2D-08	[C1]	0.55	2	71	230/400	50	Δ/Y	2.35/1.36	2800	60	2550	15/17/21/23
Ex II 3G c IIB T3												
REM	Curves	Nominal motor power kW	Poles	Motor size	Motor voltage V	Nominal frequency Hz	Connection	Nominal motor current A	Nominal motor speed 1/min	Max. media Temperature °C	Max. volume flow m³/h	Weight REM 11/13/18/19 kg
11-/13-/18-/19-0250-2X-08-2G	[C2]	0.55	2	71	230/400	50	Δ/Y	2.42/1.40	2785	60	2550	15/17/21/23
60 Hz												
REM	Curves	Nominal motor power kW	Poles	Motor size	Motor voltage V	Nominal frequency Hz	Connection	Nominal motor current A	Nominal motor speed 1/min	Max. media Temperature °C	Max. volume flow m³/h	Weight REM 11/13/18/19 kg
11-/13-/18-/19-0250-2W-10-60	[C3]	0.86	2	80 M	460	60	Y	1.67	3366	60	3080	17/20/24/26

Motor protection can take place through motor protection units with bi-metallic releases (EUM 33) or via a thermistor (NTC) temperature sensor in connection with a thermistor (NTC)-release device (EUM 03). See chapter "Accessories".

The direction of rotation is determined looking from the drive side. Anti-clockwise rotation, symbol **LG**. Clockwise rotation, symbol **RD**.

**Dimensions** in mm, subject to change.

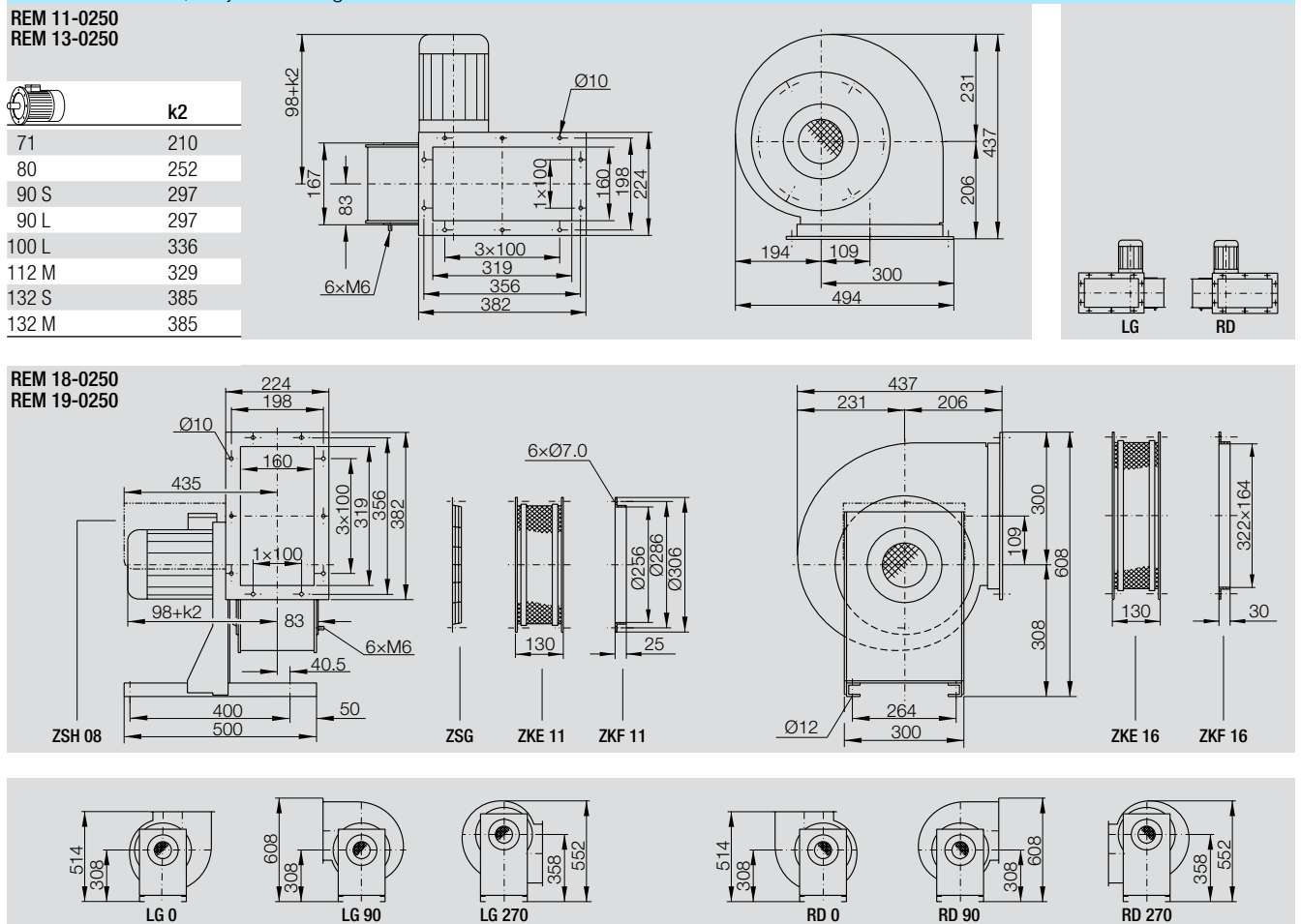

**REM 11-0280**  
**REM 13-0280**

**REM 18-0280**  
**REM 19-0280**

**Curves**

Density of media **1.2 kg/m<sup>3</sup>**.  
Measured in installation **B** according to **ISO 5801** (ducted).

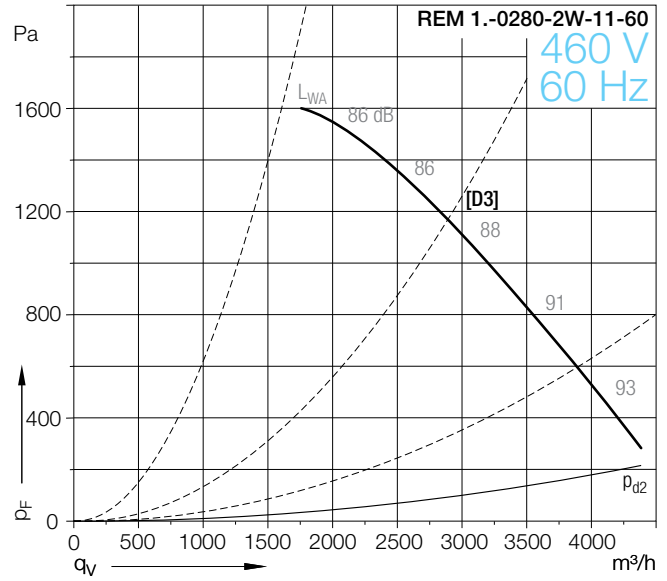
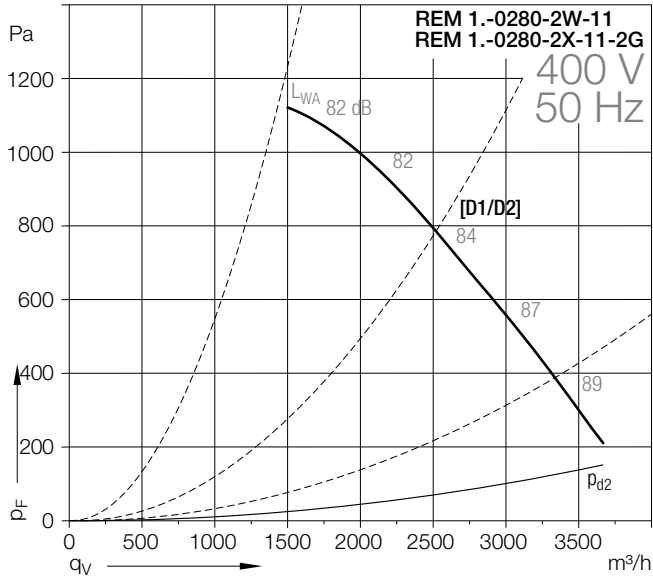
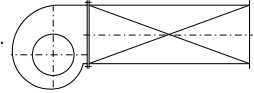

**REM 11-0280**  
**REM 13-0280**

**REM 18-0280**  
**REM 19-0280**

Technical Data												
REM	Curves	Nominal motor power kW	Poles	Motor size	Motor voltage V	Nominal frequency Hz	Connection	Nominal motor current A	Nominal motor speed 1/min	Max. media Temperature °C	Max. volume flow m³/h	Weight REM 11/13/18/19 kg
11-/13-/18-/19-0280-2W-11	[D1]	1.10	2	80 M	230/400	50	Δ/Y	4.20/2.40	2835	60	3760	18/21/26/29
Ex II 3G c IIB T3												
REM	Curves	Nominal motor power kW	Poles	Motor size	Motor voltage V	Nominal frequency Hz	Connection	Nominal motor current A	Nominal motor speed 1/min	Max. media Temperature °C	Max. volume flow m³/h	Weight REM 11/13/18/19 kg
11-/13-/18-/19-0280-2X-11-2G	[D2]	1.10	2	80	230/400	50	Δ/Y	4.33/2.50	2855	60	3760	18/21/26/29
60 Hz												
REM	Curves	Nominal motor power kW	Poles	Motor size	Motor voltage V	Nominal frequency Hz	Connection	Nominal motor current A	Nominal motor speed 1/min	Max. media Temperature °C	Max. volume flow m³/h	Weight REM 11/13/18/19 kg
11-/13-/18-/19-0280-2W-11-60	[D3]	1.27	2	80 M	460	60	Y	2.40	3402	60	4470	18/21/26/29

Motor protection can take place through motor protection units with bi-metallic releases (EUM 33) or via a thermistor (NTC) temperature sensor in connection with a thermistor (NTC)-release device (EUM 03). See chapter "Accessories".

The direction of rotation is determined looking from the drive side. Anti-clockwise rotation, symbol **LG**. Clockwise rotation, symbol **RD**.

**Dimensions** in mm, subject to change.

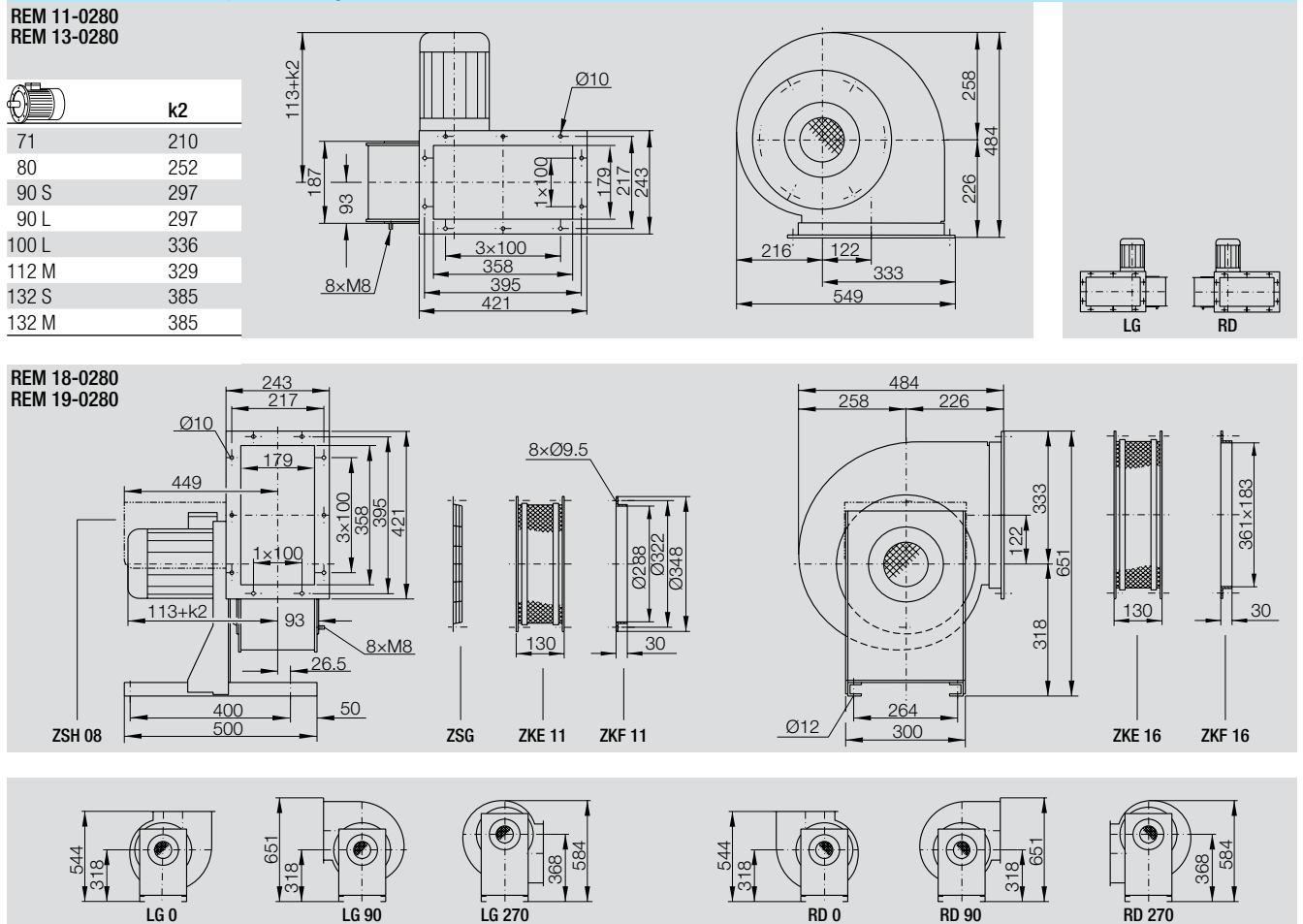

**REM 11-0315**  
**REM 13-0315**

**REM 18-0315**  
**REM 19-0315**

**Curves**

Density of media **1.2 kg/m<sup>3</sup>**.  
Measured in installation **B** according to **ISO 5801** (ducted).

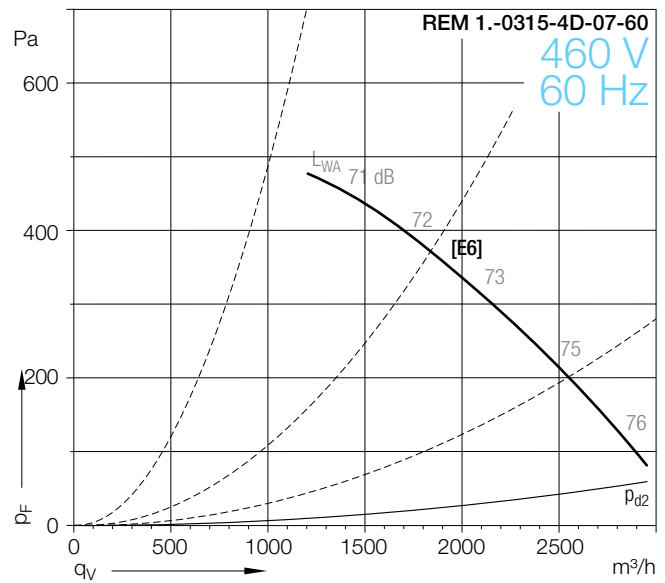
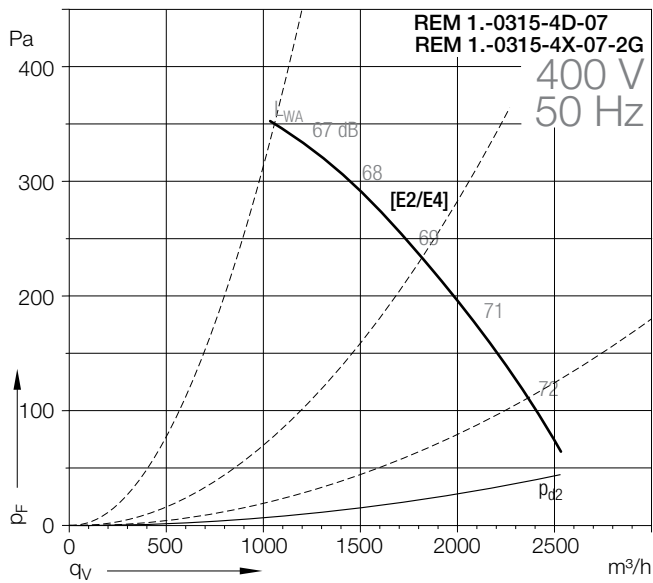
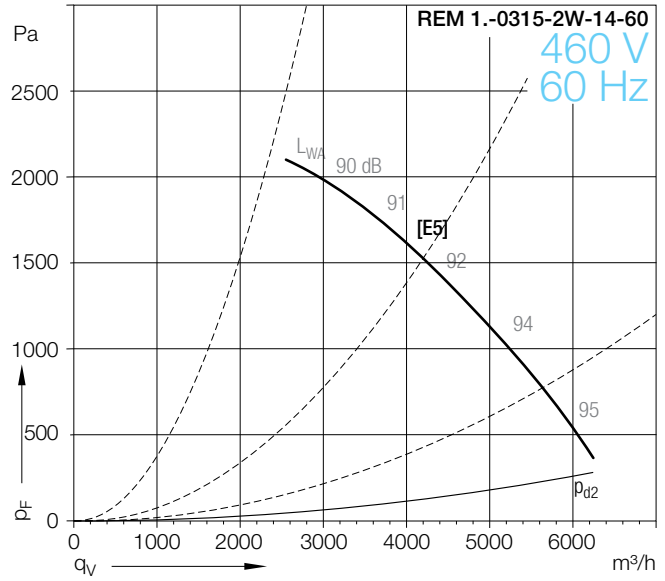
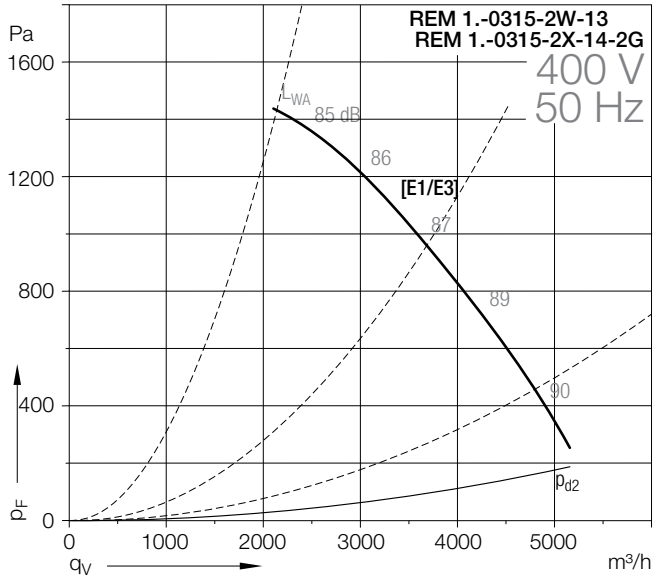
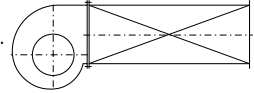



# REM 11-0315 REM 13-0315

# REM 18-0315 REM 19-0315

## Technical Data

REM	Curves	Nominal motor power kW	Poles	Motor size	Motor voltage V	Nominal frequency Hz	Connection	Nominal motor current A	Nominal motor speed 1/min	Max. media Temperature °C	Max. volume flow m³/h	Weight REM 11/13/18/19 kg
11-/13-/18-/19-	[E1]	1.50	2	90 S	230/400	50	Δ/Y	5.50/3.15	2885	60	5250	25/28/33/36
0315-2W-13	[E1]	1.50	2	90 S	230/400	50	Δ/Y	5.50/3.15	2885	60	5250	25/28/33/36
0315-4D-07	[E2]	0.25	4	71	230/400	50	Δ/Y	1.32/0.76	1350	60	2600	19/22/26/29

REM	Curves	Nominal motor power kW	Poles	Motor size	Motor voltage V	Nominal frequency Hz	Connection	Nominal motor current A	Nominal motor speed 1/min	Max. media Temperature °C	Max. volume flow m³/h	Weight REM 11/13/18/19 kg
11-/13-/18-/19-	[E3]	1.85	2	90 L	230/400	50	Δ/Y	6.85/3.95	2860	60	5250	28/31/36/39
0315-2X-14-2G	[E3]	1.85	2	90 L	230/400	50	Δ/Y	6.85/3.95	2860	60	5250	28/31/36/39
0315-4X-07-2G	[E4]	0.25	4	71	230/400	50	Δ/Y	1.39/0.80	1310	60	2600	19/22/26/29

REM	Curves	Nominal motor power kW	Poles	Motor size	Motor voltage V	Nominal frequency Hz	Connection	Nominal motor current A	Nominal motor speed 1/min	Max. media Temperature °C	Max. volume flow m³/h	Weight REM 11/13/18/19 kg
11-/13-/18-/19-	[E5]	2.55	2	90 L	460	60	Y	4.50	3468	60	6360	28/31/36/39
0315-2W-14-60	[E5]	2.55	2	90 L	460	60	Y	4.50	3468	60	6360	28/31/36/39
0315-4D-07-60	[E6]	0.29	4	71	460	60	Y	0.76	1620	60	3000	19/22/14/29

Motor protection can take place through motor protection units with bi-metallic releases (EUM 33) or via a thermistor (NTC) temperature sensor in connection with a thermistor (NTC)-release device (EUM 03). See chapter "Accessories".

The direction of rotation is determined looking from the drive side. Anti-clockwise rotation, symbol **LG**. Clockwise rotation, symbol **RD**.

### Dimensions in mm, subject to change.

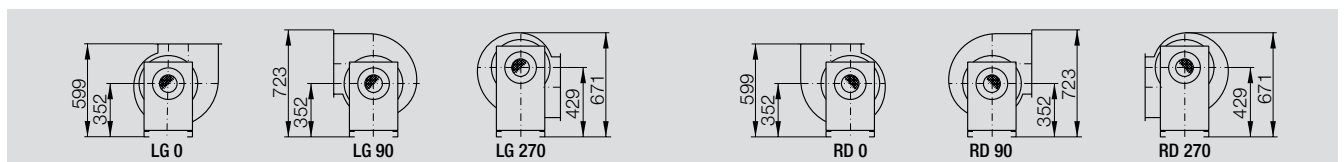
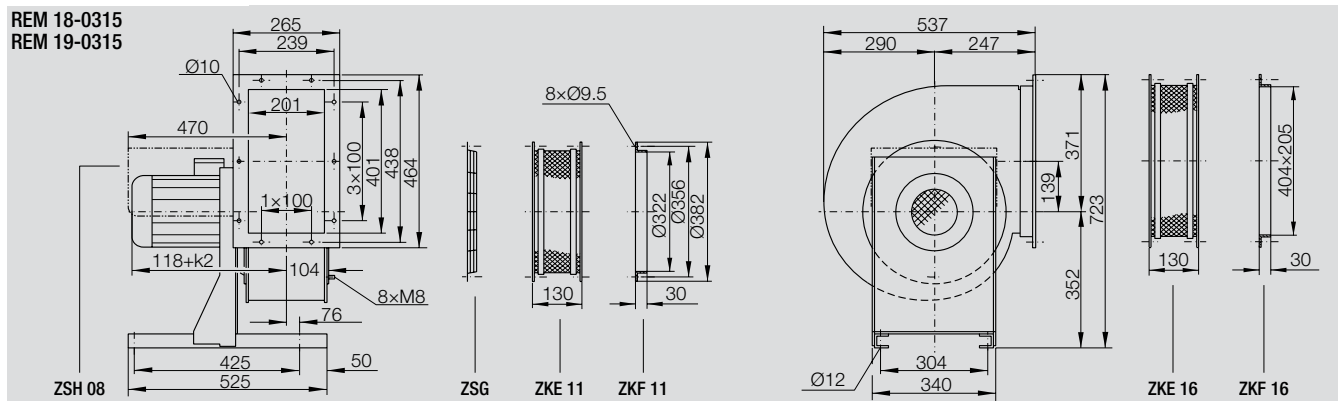
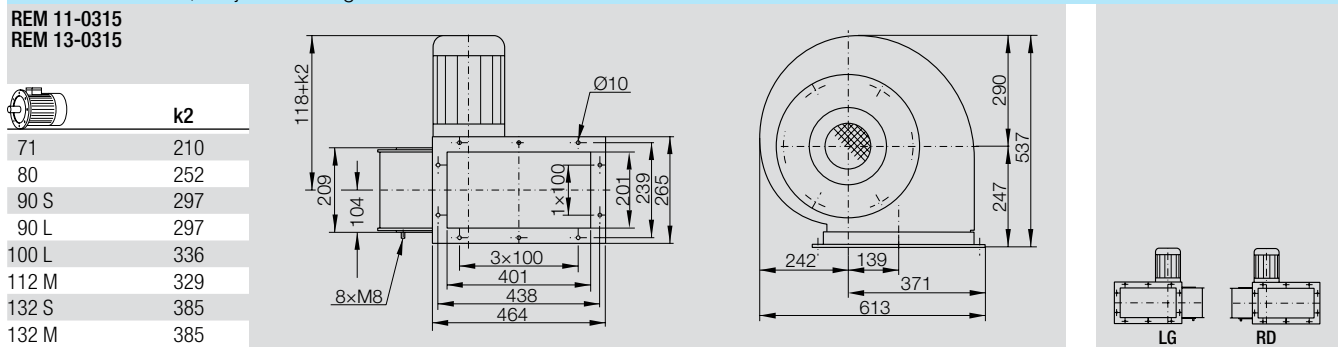

**REM 11-0355**  
**REM 13-0355**

**REM 18-0355**  
**REM 19-0355**

**Curves**

Density of media **1.2 kg/m³**.  
Measured in installation **B** according to **ISO 5801** (ducted).

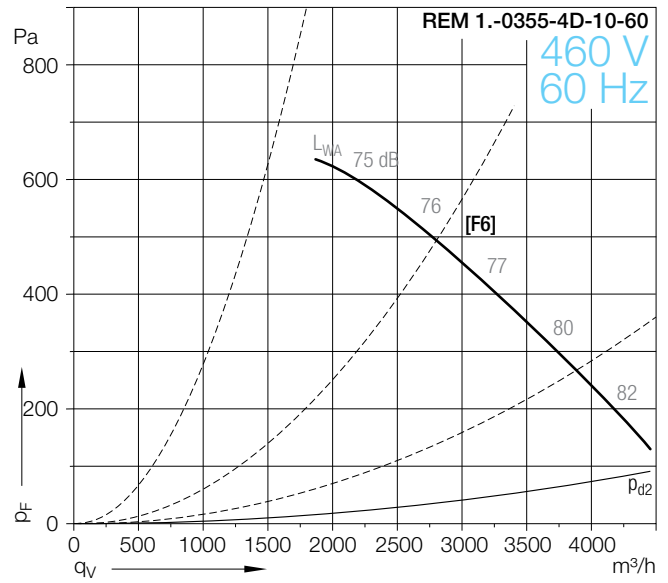
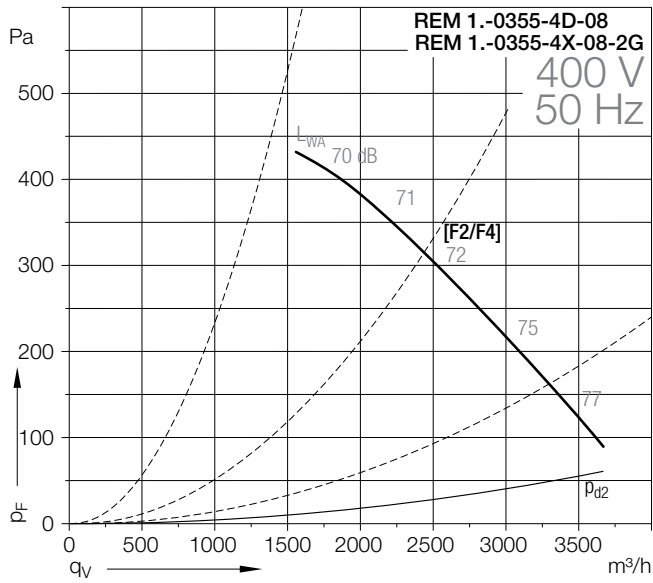
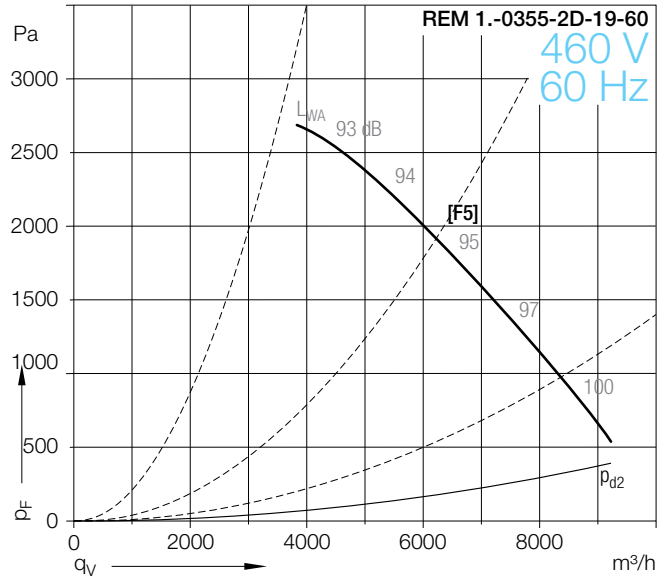
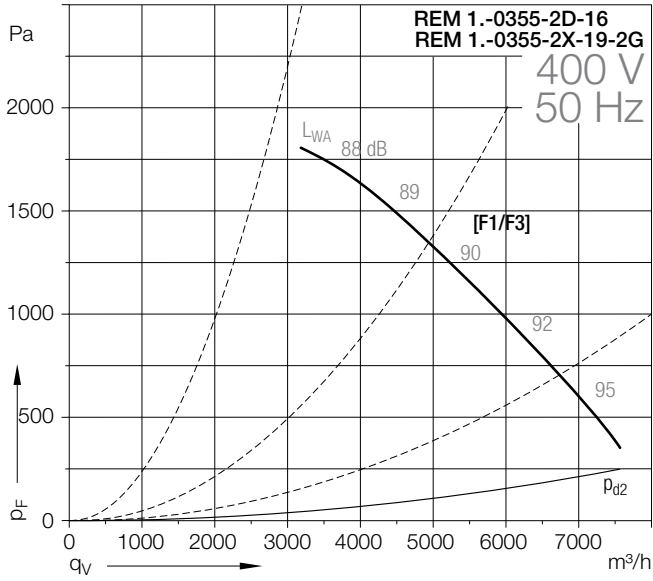
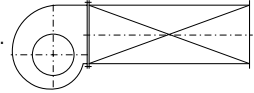

# REM 11-0355 REM 13-0355

# REM 18-0355 REM 19-0355

## Technical Data

REM	Curves	Nominal motor power kW	Poles	Motor size	Motor voltage V	Nominal frequency Hz	Connection	Nominal motor current A	Nominal motor speed 1/min	Max. media Temperature °C	Max. volume flow m³/h	Weight REM 11/13/18/19 kg
0355-2W-16	[F1]	3.00	2	100 L	230/400	50	Δ/Y	10.60/6.10	2905	60	7580	35/40/44/49
0355-4D-08	[F2]	0.37	4	71	230/400	50	Δ/Y	1.78/1.03	1370	60	3780	23/28/32/37

REM	Curves	Nominal motor power kW	Poles	Motor size	Motor voltage V	Nominal frequency Hz	Connection	Nominal motor current A	Nominal motor speed 1/min	Max. media Temperature °C	Max. volume flow m³/h	Weight REM 11/13/18/19 kg
0355-2X-19-2G	[F3]	3.30	2	112 M	230/400	50	Δ/Y	11.60/6.70	2875	60	7770	53/58/62/67
0355-4X-08-2G	[F4]	0.37	4	71	230/400	50	Δ/Y	1.91/1.10	1355	60	3780	23/28/32/37

REM	Curves	Nominal motor power kW	Poles	Motor size	Motor voltage V	Nominal frequency Hz	Connection	Nominal motor current A	Nominal motor speed 1/min	Max. media Temperature °C	Max. volume flow m³/h	Weight REM 11/13/18/19 kg
0355-2W-19-60	[F5]	4.60	2	112 M	460	60	Δ	7.70	3550	60	9222	41/46/50/55
0355-4D-10-60	[F6]	0.63	4	80	460	60	Y	1.45	1674	60	4590	26/31/16/40

Motor protection can take place through motor protection units with bi-metallic releases (EUM 33) or via a thermistor (NTC) temperature sensor in connection with a thermistor (NTC)-release device (EUM 03). See chapter "Accessories".

The direction of rotation is determined looking from the drive side. Anti-clockwise rotation, symbol **LG**. Clockwise rotation, symbol **RD**.

### Dimensions in mm, subject to change.

REM 11-0355  
REM 13-0355

	k2
71	210
80	252
90 S	297
90 L	297
100 L	336
112 M	329
132 S	385
132 M	385

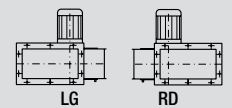
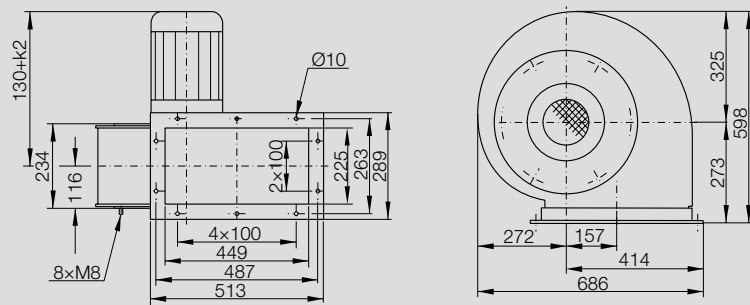

REM 18-0355  
REM 19-0355

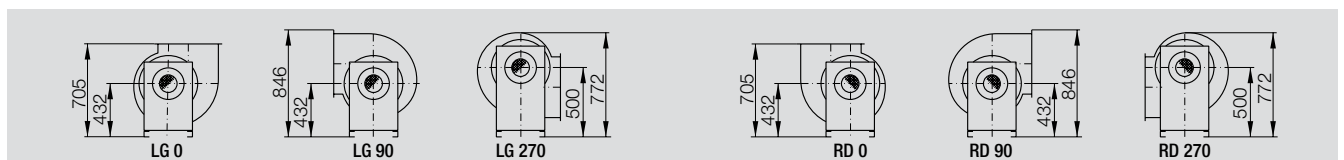
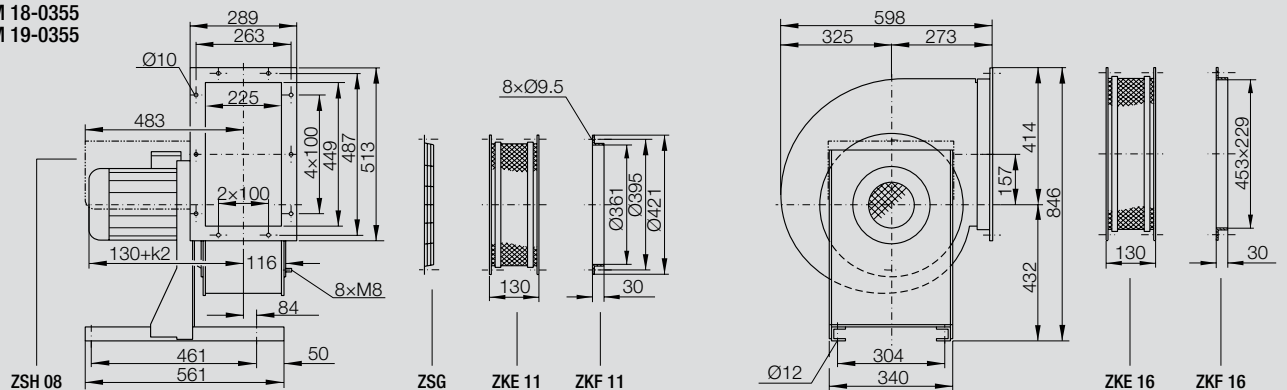

**REM 11-0400**  
**REM 13-0400**

**REM 18-0400**  
**REM 19-0400**

**Curves**

Density of media **1.2 kg/m<sup>3</sup>**.  
Measured in installation **B** according to **ISO 5801** (ducted).

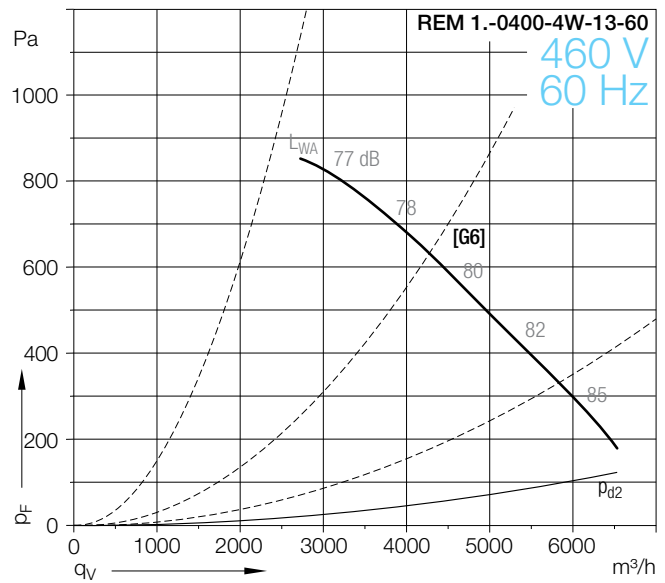
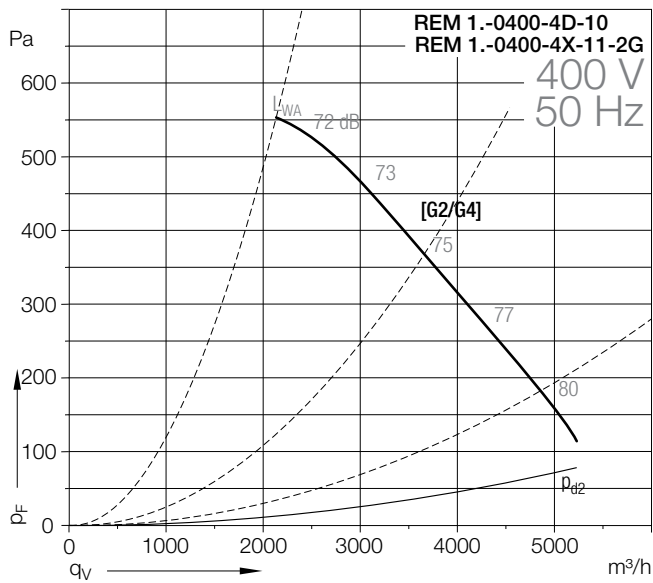
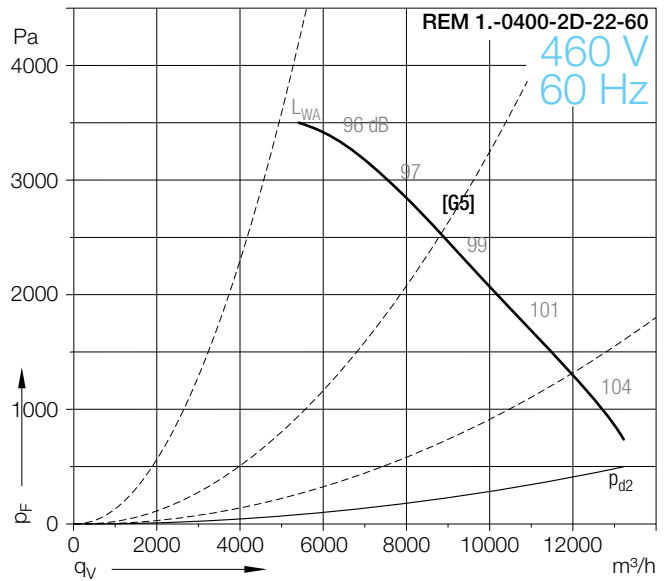
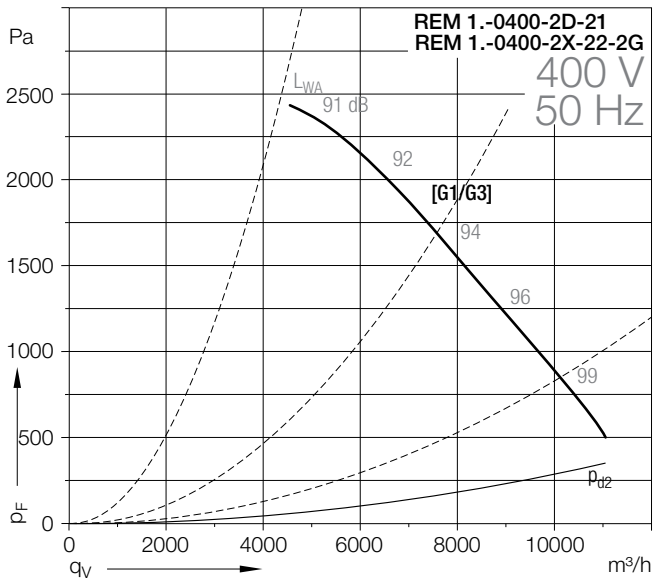
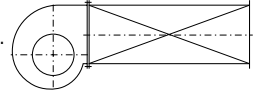

# REM 11-0400 REM 13-0400

# REM 18-0400 REM 19-0400

## Technical Data

REM	Curves	Nominal motor power kW	Poles	Motor size	Motor voltage V	Nominal frequency Hz	Connection	Nominal motor current A	Nominal motor speed 1/min	Max. media Temperature °C	Max. volume flow m³/h	Weight REM 11/13/18/19 kg
11-/13-/18-/19-	[G1]	5.50	2	132 S	400	50	△	10.40	2905	60	11055	-/77/-/-
0400-2W-21	[G1]	5.50	2	132 S	400	50	△	10.40	2905	60	11055	-/77/-/-
0400-4D-10	[G2]	0.55	4	80	230/400	50	△/Y	2.50/1.45	1395	60	5370	29/32/60/63

REM	Curves	Nominal motor power kW	Poles	Motor size	Motor voltage V	Nominal frequency Hz	Connection	Nominal motor current A	Nominal motor speed 1/min	Max. media Temperature °C	Max. volume flow m³/h	Weight REM 11/13/18/19 kg
11-/13-/18-/19-	[G3]	5.50	2	132 S	400/690	50	△/Y	10.70/6.20	2920	60	11320	-/84/-/-
0400-2X-22-2G	[G3]	5.50	2	132 S	400/690	50	△/Y	10.70/6.20	2920	60	11320	-/84/-/-
0400-4X-11-2G	[G4]	0.75	4	80	230/400	50	△/Y	3.55/2.05	1375	60	5370	29/32/60/64

REM	Curves	Nominal motor power kW	Poles	Motor size	Motor voltage V	Nominal frequency Hz	Connection	Nominal motor current A	Nominal motor speed 1/min	Max. media Temperature °C	Max. volume flow m³/h	Weight REM 11/13/18/19 kg
11-/13-/18-/19-	[G5]	8.60	2	132 S	460	60	△	13.80	3550	60	13279	-/81/-/-
0400-2W-22-60	[G5]	8.60	2	132 S	460	60	△	13.80	3550	60	13279	-/81/-/-
0400-4W-13-60	[G6]	1.27	4	90 S	460	60	Y	2.50	1710	60	6700	33/36/64/67

For "REM ...0400-2D-21", "...-2X-22-2G" and "...-2D-22-60" only model "13-" available!

Motor protection can take place through motor protection units with bi-metallic releases (EUM 33) or via a thermistor (NTC) temperature sensor in connection with a thermistor (NTC)-release device (EUM 03). See chapter "Accessories".

The direction of rotation is determined looking from the drive side. Anti-clockwise rotation, symbol **LG**. Clockwise rotation, symbol **RD**.

### Dimensions in mm, subject to change.

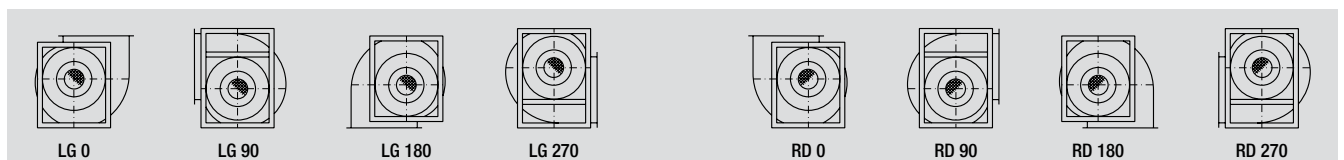
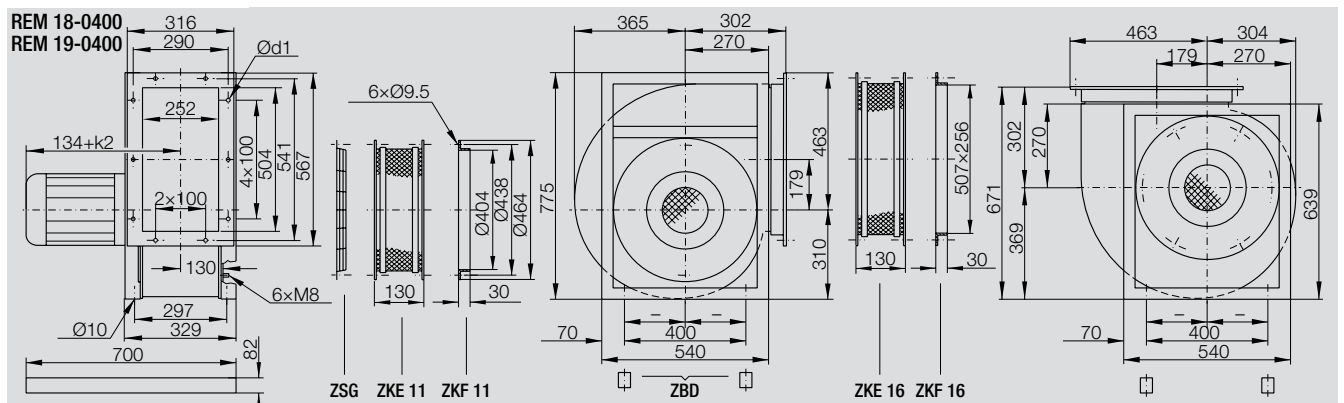
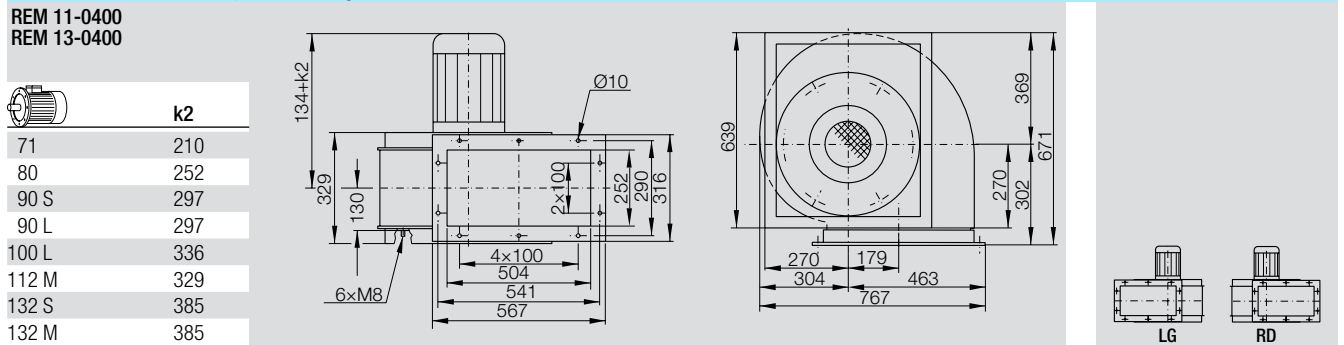

**REM 11-0450**  
**REM 13-0450**

**REM 18-0450**  
**REM 19-0450**

**Curves**

Density of media **1.2 kg/m<sup>3</sup>**.  
Measured in installation **B** according to **ISO 5801** (ducted).

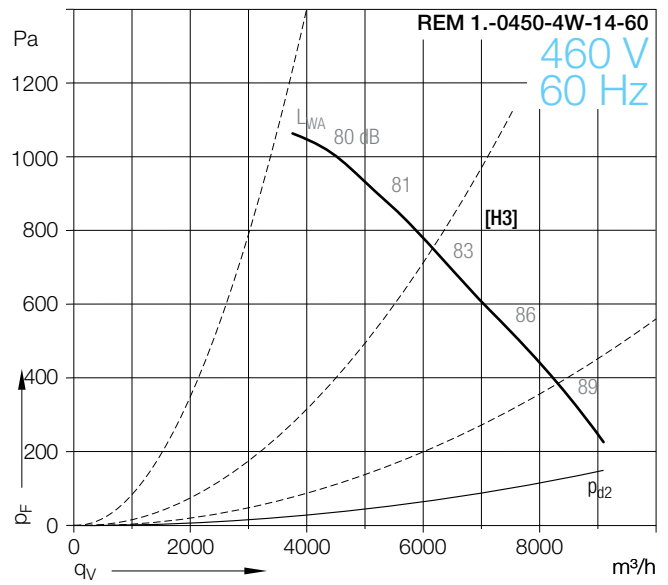
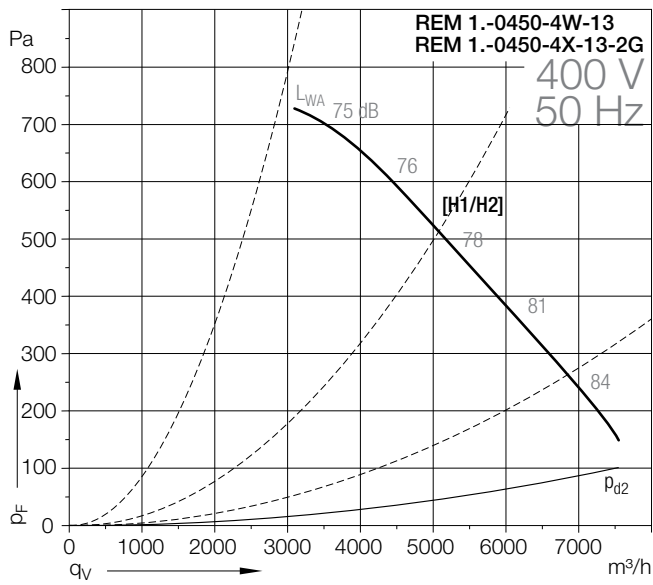
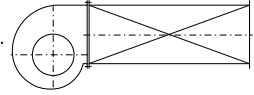

# REM 11-0450 REM 13-0450

# REM 18-0450 REM 19-0450

Technical Data												
REM	Curves	Nominal motor power kW	Poles	Motor size	Motor voltage V	Nominal frequency Hz	Connection	Nominal motor current A	Nominal motor speed 1/min	Max. media Temperature °C	Max. volume flow m³/h	Weight REM 11/13/18/19 kg
11-/13-/18-/19-	[H1]	1.10	4	90 S	230/400	50	Δ/Y	4.30/2.50	1425	60	7720	37/43/63/68
Ex II 3G c IIB T3												
REM	Curves	Nominal motor power kW	Poles	Motor size	Motor voltage V	Nominal frequency Hz	Connection	Nominal motor current A	Nominal motor speed 1/min	Max. media Temperature °C	Max. volume flow m³/h	Weight REM 11/13/18/19 kg
11-/13-/18-/19-	[H2]	1.00	4	90 S	230/400	50	Δ/Y	4.33/2.50	1420	60	7720	42/47/76/81
60 Hz												
REM	Curves	Nominal motor power kW	Poles	Motor size	Motor voltage V	Nominal frequency Hz	Connection	Nominal motor current A	Nominal motor speed 1/min	Max. media Temperature °C	Max. volume flow m³/h	Weight REM 11/13/18/19 kg
11-/13-/18-/19-	[H3]	1.75	4	90 L	460	60	Y	3.30	1722	60	9360	40/46/26/71

Motor protection can take place through motor protection units with bi-metallic releases (EUM 33) or via a thermistor (NTC) temperature sensor in connection with a thermistor (NTC)-release device (EUM 03). See chapter "Accessories".

The direction of rotation is determined looking from the drive side. Anti-clockwise rotation, symbol **LG**. Clockwise rotation, symbol **RD**.

**Dimensions** in mm, subject to change.

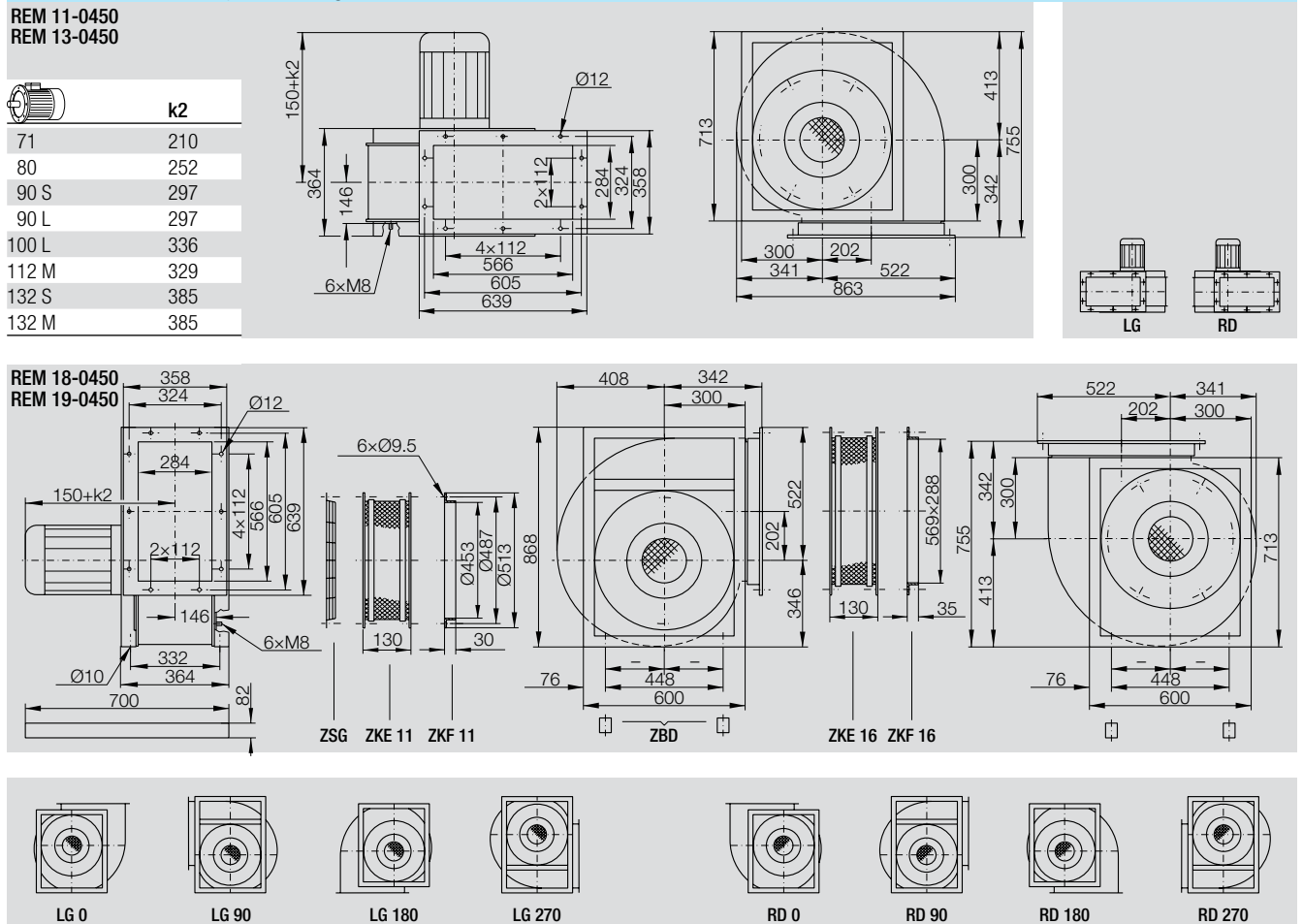

**REM 11-0500**  
**REM 13-0500**

**REM 18-0500**  
**REM 19-0500**

**Curves**

Density of media **1.2 kg/m<sup>3</sup>**.  
Measured in installation **B** according to **ISO 5801** (ducted).

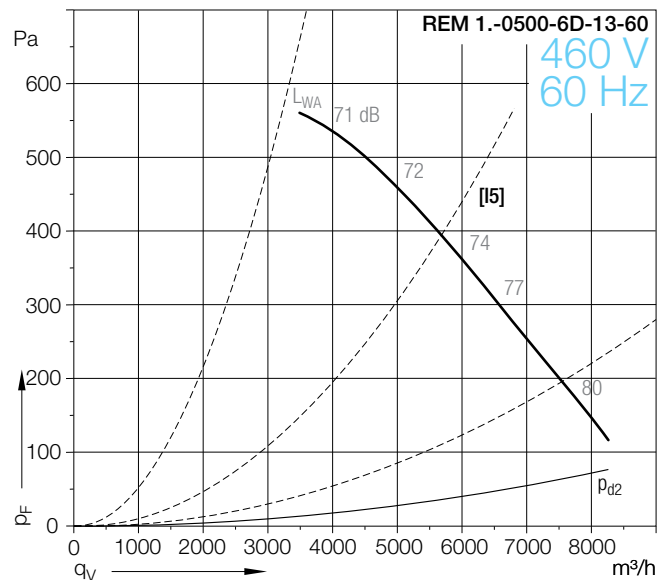
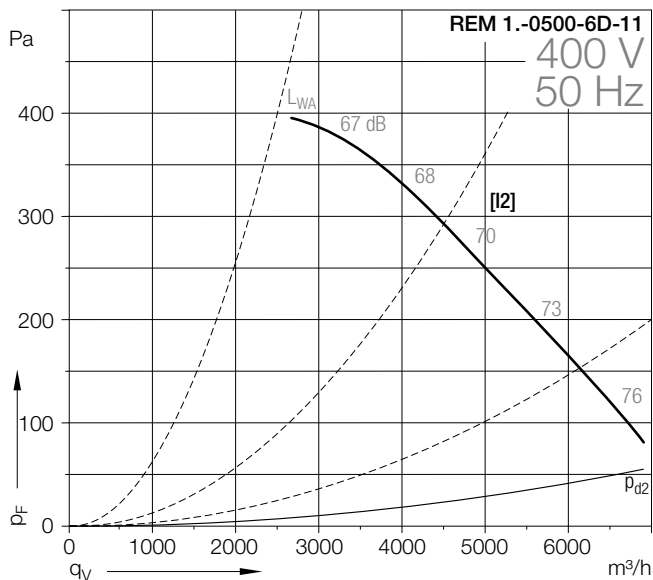
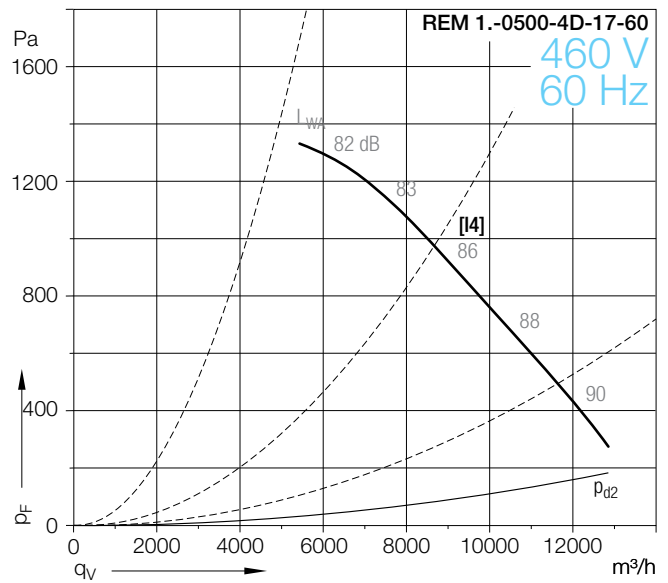
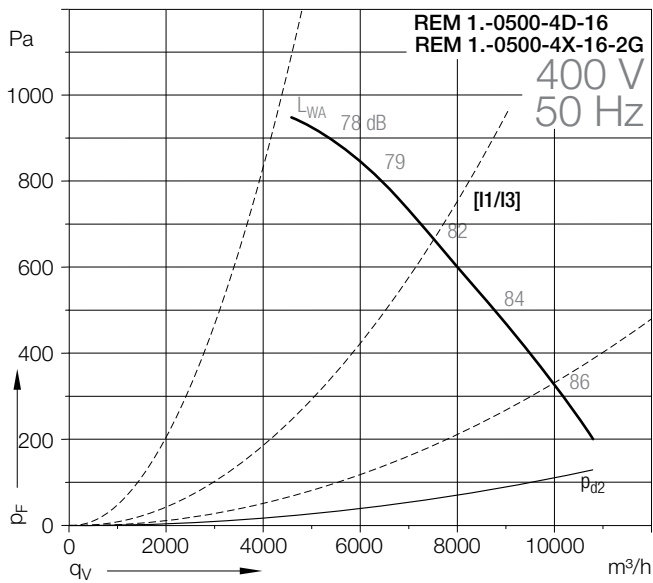
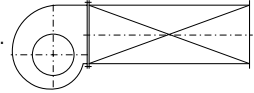



# REM 11-0500 REM 13-0500

# REM 18-0500 REM 19-0500

## Technical Data

REM	Curves	Nominal motor power kW	Poles	Motor size	Motor voltage V	Nominal frequency Hz	Connection	Nominal motor current A	Nominal motor speed 1/min	Max. media Temperature °C	Max. volume flow m³/h	Weight REM 11/13/18/19 kg
11-/13-/18-/19-												
0500-4W-16	[1]	2.20	4	100 L	230/400	50	Δ/Y	8.05/4.65	1455	60	10825	59/65/97/103
0500-6D-11	[2]	0.55	6	80	230/400	50	Δ/Y	2.80/1.60	910	60	7120	46/52/84/90

REM	Curves	Nominal motor power kW	Poles	Motor size	Motor voltage V	Nominal frequency Hz	Connection	Nominal motor current A	Nominal motor speed 1/min	Max. media Temperature °C	Max. volume flow m³/h	Weight REM 11/13/18/19 kg
11-/13-/18-/19-												
0500-4X-16-2G	[3]	2.00	4	100 L	230/400	50	Δ/Y	7.80/4.50	1420	60	11160	68/74/106/112

REM	Curves	Nominal motor power kW	Poles	Motor size	Motor voltage V	Nominal frequency Hz	Connection	Nominal motor current A	Nominal motor speed 1/min	Max. media Temperature °C	Max. volume flow m³/h	Weight REM 11/13/18/19 kg
11-/13-/18-/19-												
0500-4W-17-60	[4]	3.45	4	100 L	460	60	Y	6.00	1755	60	12855	63/69/101/107
0500-6W-13-60	[5]	0.86	6	90 S	460	60	Y	2.05	1130	60	8290	52/58/90/96

Motor protection can take place through motor protection units with bi-metallic releases (EUM 33) or via a thermistor (NTC) temperature sensor in connection with a thermistor (NTC)-release device (EUM 03). See chapter "Accessories".

The direction of rotation is determined looking from the drive side. Anti-clockwise rotation, symbol **LG**. Clockwise rotation, symbol **RD**.

### Dimensions in mm, subject to change.

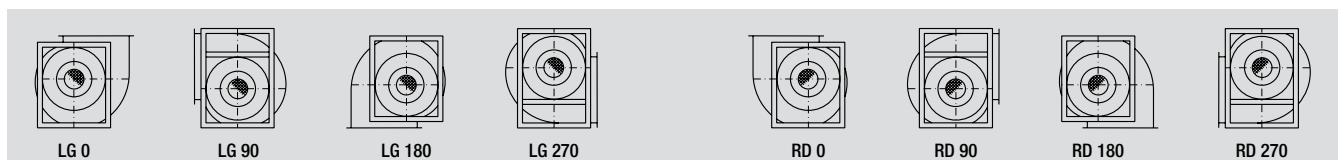
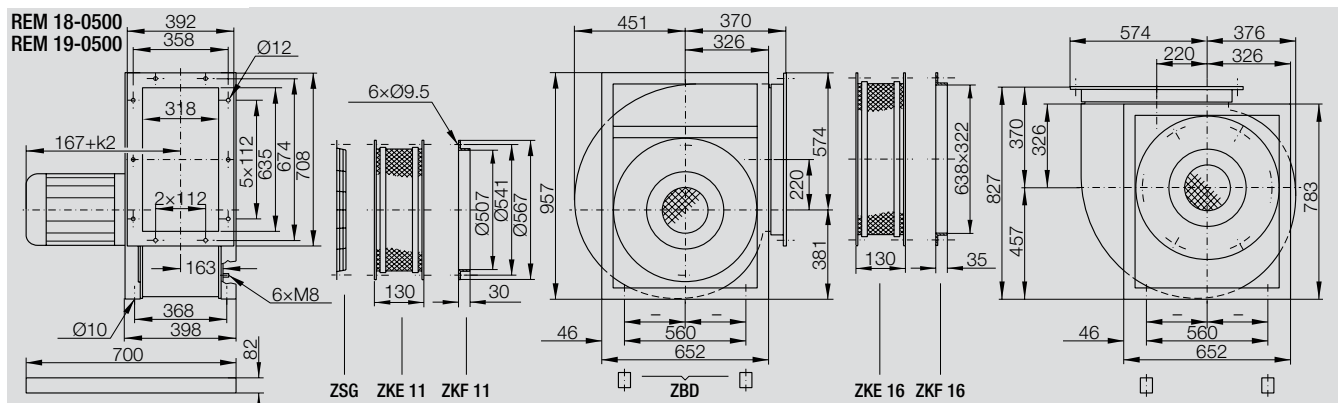
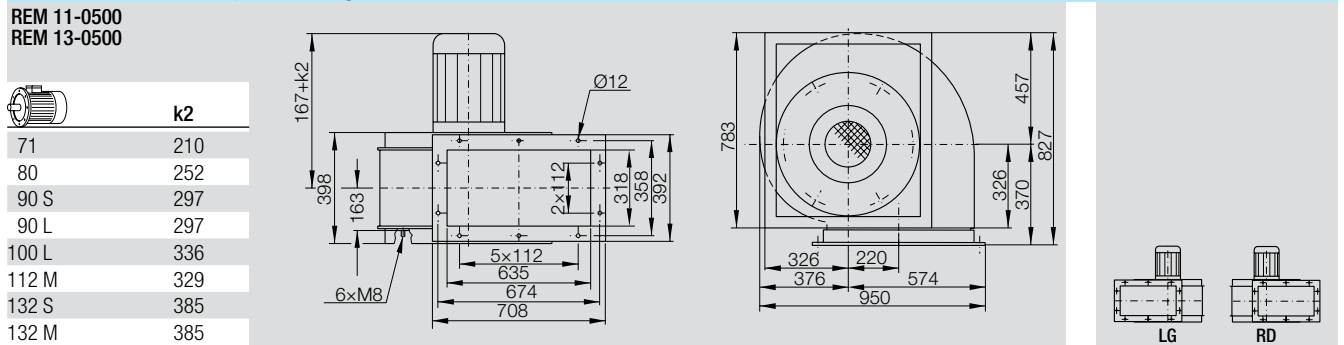

**REM 11-0560**  
**REM 13-0560**

**REM 18-0560**  
**REM 19-0560**

**Curves**

Density of media **1.2 kg/m<sup>3</sup>**.  
Measured in installation **B** according to **ISO 5801** (ducted).

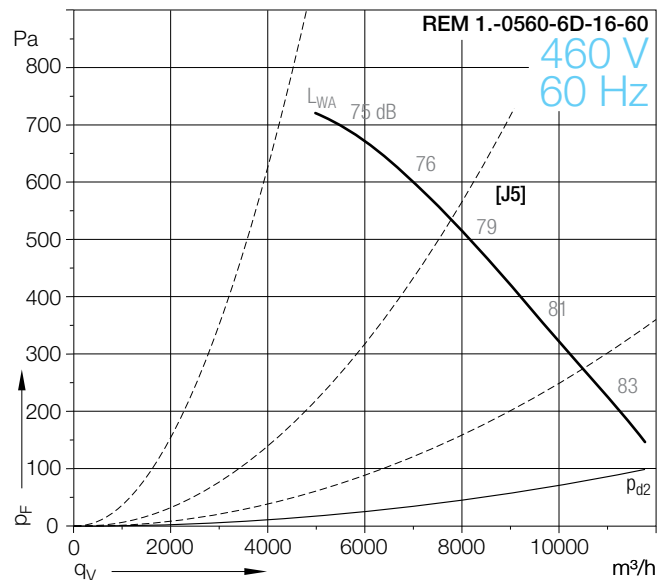
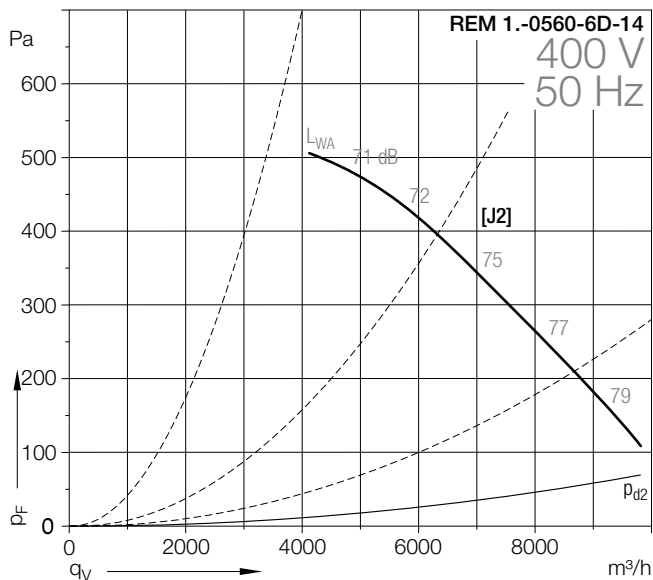
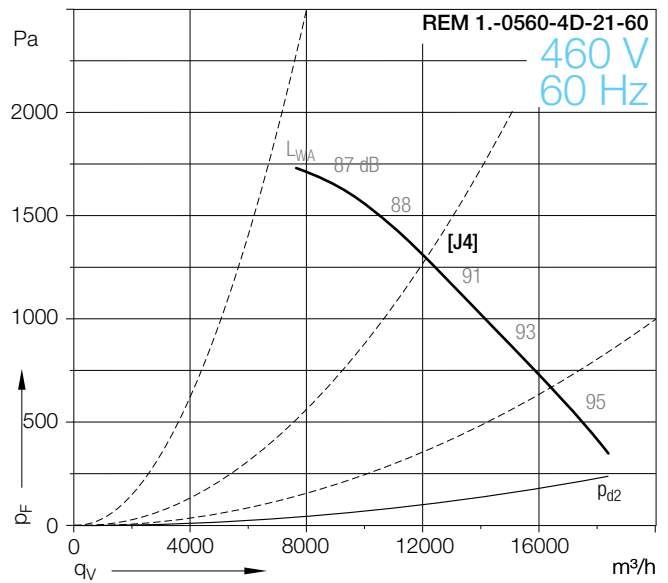
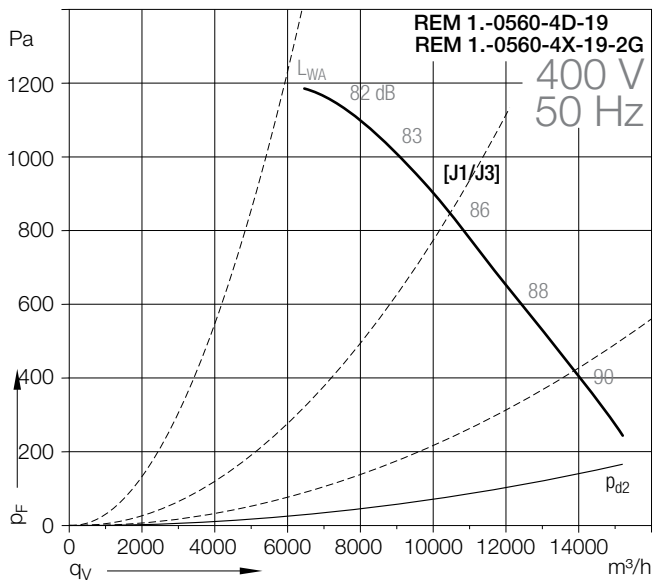
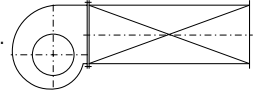

# REM 11-0560 REM 13-0560

# REM 18-0560 REM 19-0560

## Technical Data

REM	Curves	Nominal motor power kW	Poles	Motor size	Motor voltage V	Nominal frequency Hz	Connection	Nominal motor current A	Nominal motor speed 1/min	Max. media Temperature °C	Max. volume flow m³/h	Weight REM 11/13/18/19 kg
0560-4W-19	[J1]	4.00	4	112 M	400	50	△	8.20	1460	60	15200	89/96/135/142
0560-6W-14	[J2]	1.10	6	90 L	230/400	50	△/Y	5.00/2.90	940	60	9840	68/75/114/121

REM	Curves	Nominal motor power kW	Poles	Motor size	Motor voltage V	Nominal frequency Hz	Connection	Nominal motor current A	Nominal motor speed 1/min	Max. media Temperature °C	Max. volume flow m³/h	Weight REM 11/13/18/19 kg
0560-4X-19-2G	[J3]	3.60	4	112 M	230/400	50	△/Y	13.00/7.50	1435	60	15640	91/98/137/144

REM	Curves	Nominal motor power kW	Poles	Motor size	Motor voltage V	Nominal frequency Hz	Connection	Nominal motor current A	Nominal motor speed 1/min	Max. media Temperature °C	Max. volume flow m³/h	Weight REM 11/13/18/19 kg
0560-4W-21-60	[J4]	6.30	4	132 S	460	60	△	11.00	1765	60	18350	102/109/148/155
0560-6W-16-60	[J5]	1.75	6	100 L	460	60	Y	3.50	1170	60	11770	74/81/120/127

Motor protection can take place through motor protection units with bi-metallic releases (EUM 33) or via a thermistor (NTC) temperature sensor in connection with a thermistor (NTC)-release device (EUM 03). See chapter "Accessories".

The direction of rotation is determined looking from the drive side. Anti-clockwise rotation, symbol **LG**. Clockwise rotation, symbol **RD**.

### Dimensions in mm, subject to change.

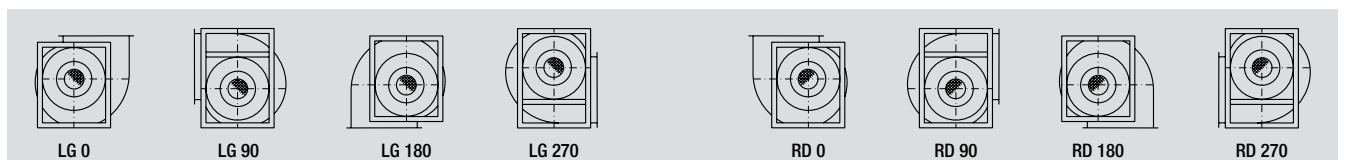
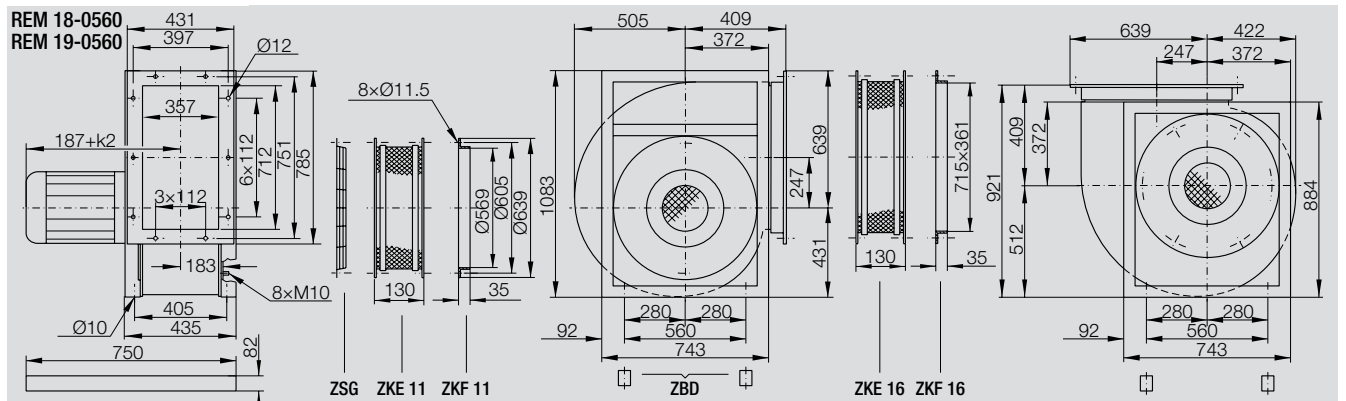
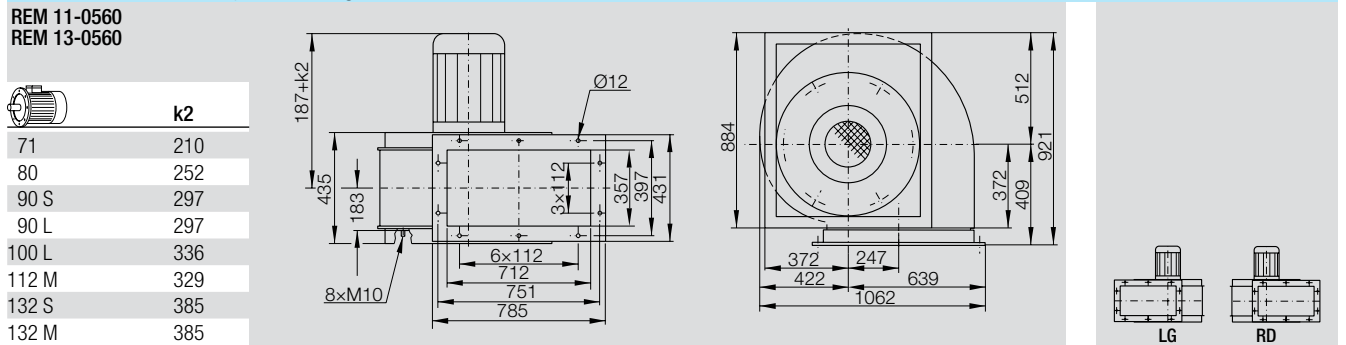

**REM 11-0630**  
**REM 13-0630**

**REM 18-0630**  
**REM 19-0630**

**Curves**

Density of media **1.2 kg/m<sup>3</sup>**.  
Measured in installation **B** according to **ISO 5801** (ducted).

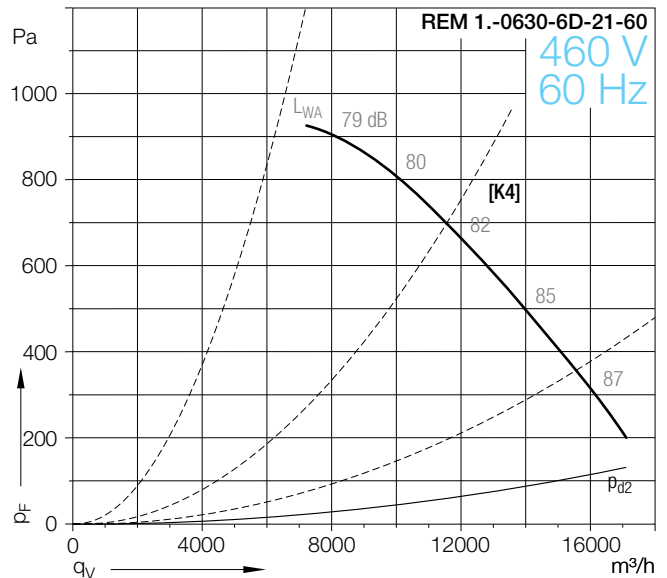
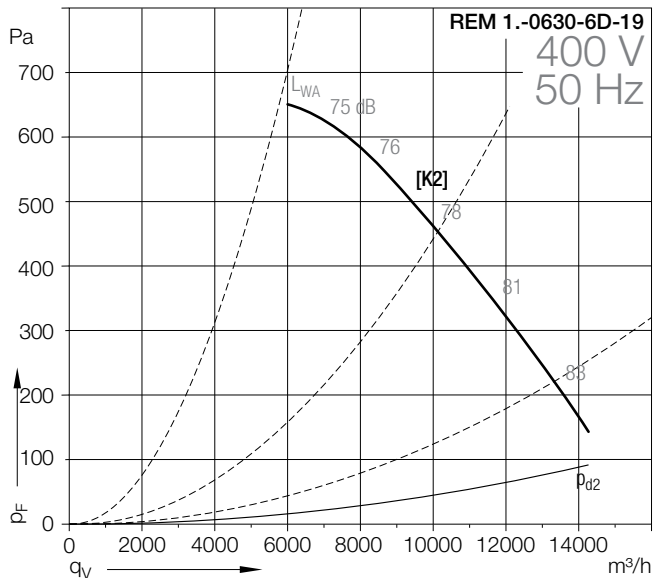
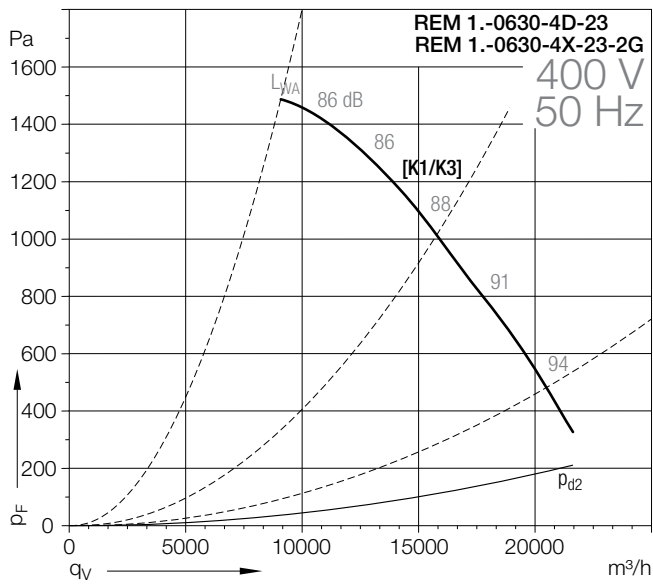
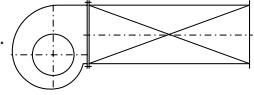

# REM 11-0630 REM 13-0630

# REM 18-0630 REM 19-0630

Technical Data												
REM	Curves	Nominal motor power kW	Poles	Motor size	Motor voltage V	Nominal frequency Hz	Connection	Nominal motor current A	Nominal motor speed 1/min	Max. media Temperature °C	Max. volume flow m³/h	Weight REM 11/13/18/19 kg
11-/13-/18-/19-	[K1]	7.50	4	132 M	400	50	△	14.80	1465	60	21750	-/130/-/-
0630-4W-23	[K1]	7.50	4	132 M	400	50	△	14.80	1465	60	21750	-/130/-/-
0630-6W-19	[K2]	2.20	6	112 M	230/400	50	△/Y	9.00/5.20	965	60	14280	99/107/155/163

Ex II 3G c IIB T3	Curves	Nominal motor power kW	Poles	Motor size	Motor voltage V	Nominal frequency Hz	Connection	Nominal motor current A	Nominal motor speed 1/min	Max. media Temperature °C	Max. volume flow m³/h	Weight REM 11/13/18/19 kg
REM 13-	[K3]	6.80	4	132 M	400/690	50	△/Y	14.00/8.10	1460	60	22370	-/135/-/-
0630-4X-23-2G	[K3]	6.80	4	132 M	400/690	50	△/Y	14.00/8.10	1460	60	22370	-/135/-/-

  

60 Hz	Curves	Nominal motor power kW	Poles	Motor size	Motor voltage V	Nominal frequency Hz	Connection	Nominal motor current A	Nominal motor speed 1/min	Max. media Temperature °C	Max. volume flow m³/h	Weight REM 11/13/18/19 kg
REM 11-/13-/18-/19-	[K4]	3.45	6	132 S	460	60	Y	6.70	1170	60	17120	108/116/164/172
0630-6W-21-60	[K4]	3.45	6	132 S	460	60	Y	6.70	1170	60	17120	108/116/164/172

For "REM ...0630-4D-23" and "...4X-23-2G" only model "13-" available!  
 Motor protection can take place through motor protection units with bi-metallic releases (EUM 33) or via a thermistor (NTC) temperature sensor in connection with a thermistor (NTC)-release device (EUM 03). See chapter "Accessories".

The direction of rotation is determined looking from the drive side.  
 Anti-clockwise rotation, symbol **LG**. Clockwise rotation, symbol **RD**.

**Dimensions** in mm, subject to change.

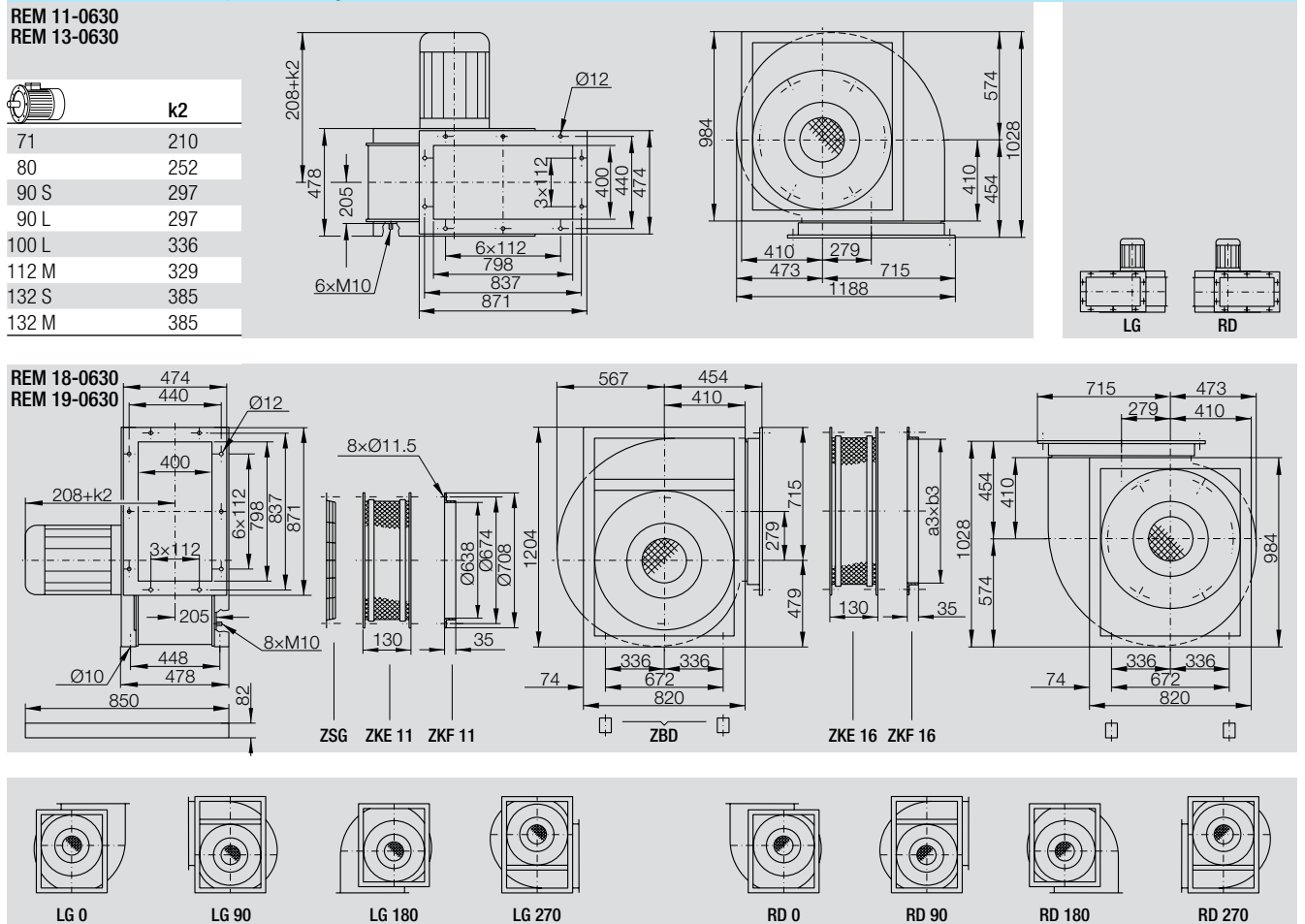

# REM 41-0200 REM 48-0200

## Curves

Density of media **1.2 kg/m<sup>3</sup>**.  
Measured in installation **B** according to **ISO 5801** (ducted).

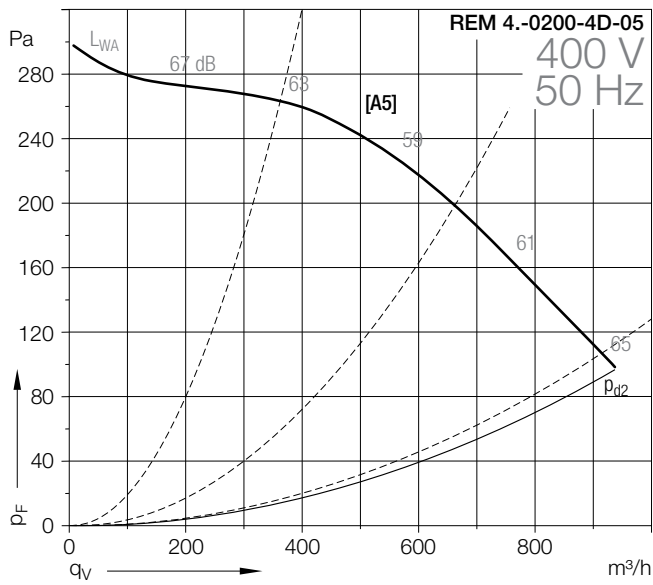
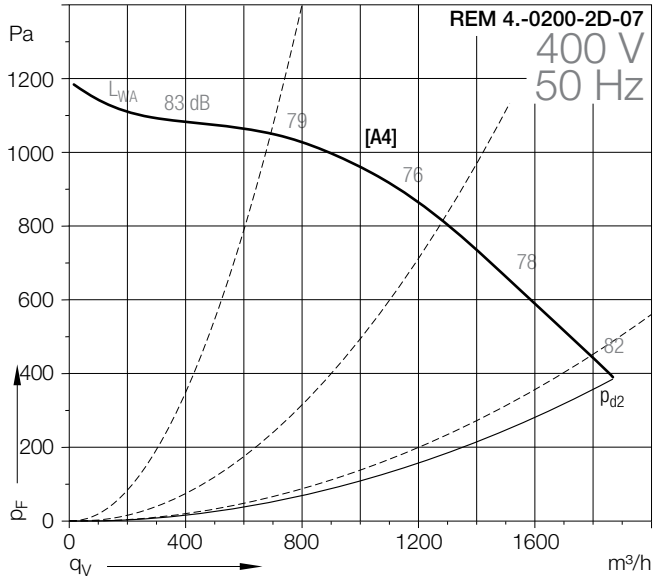
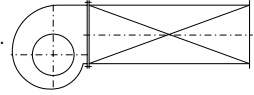

# REM 41-0200 REM 48-0200

## Technical Data

REM 41-	Curves	Nominal motor power kW	Poles	Motor size	Motor voltage V	Nominal frequency Hz	Connection	Nominal motor current A	Nominal motor speed 1/min	Max. media Temperature °C	Max. volume flow m³/h	Weight kg
0200-2D-07	[A4]	0.37	2	71 M	230/400	50	Δ/Y	1.73/1.00	2740	60	1869	17
0200-4D-05	[A5]	0.18	4	63 M	230/400	50	Δ/Y	1.00/0.58	1350	60	938	16

REM 48-	Curves	Nominal motor power kW	Poles	Motor size	Motor voltage V	Nominal frequency Hz	Connection	Nominal motor current A	Nominal motor speed 1/min	Max. media Temperature °C	Max. volume flow m³/h	Weight kg
0200-2D-07	[A4]	0.37	2	71 M	230/400	50	Δ/Y	1.73/1.00	2740	60	1869	23
0200-4D-05	[A5]	0.18	4	63 M	230/400	50	Δ/Y	1.00/0.58	1350	60	938	22

### Dimensions in mm, subject to change.

#### REM 41-0200

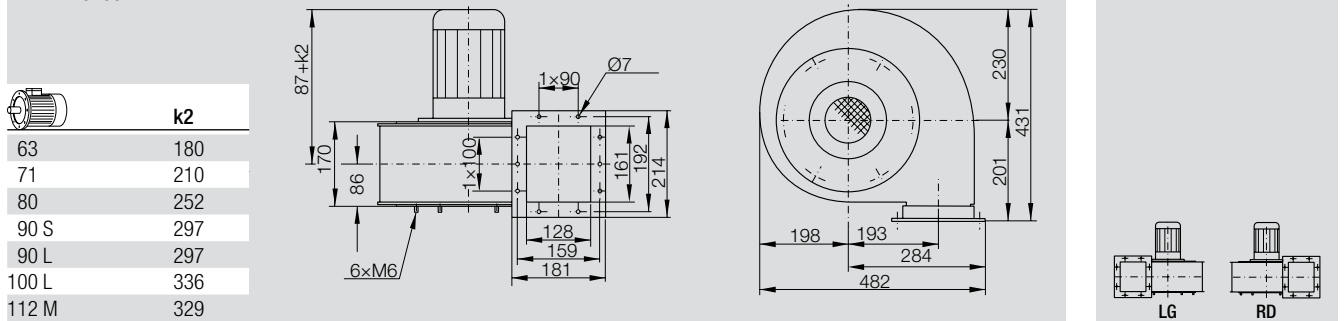

#### REM 48-0200

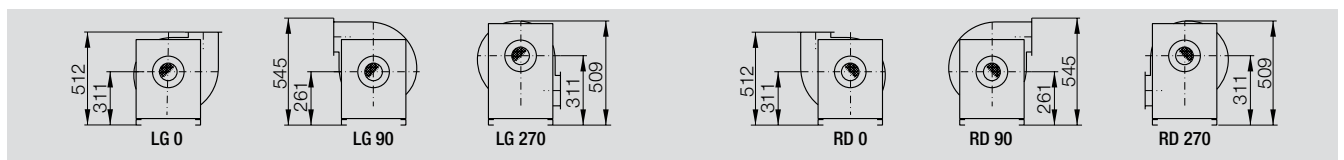
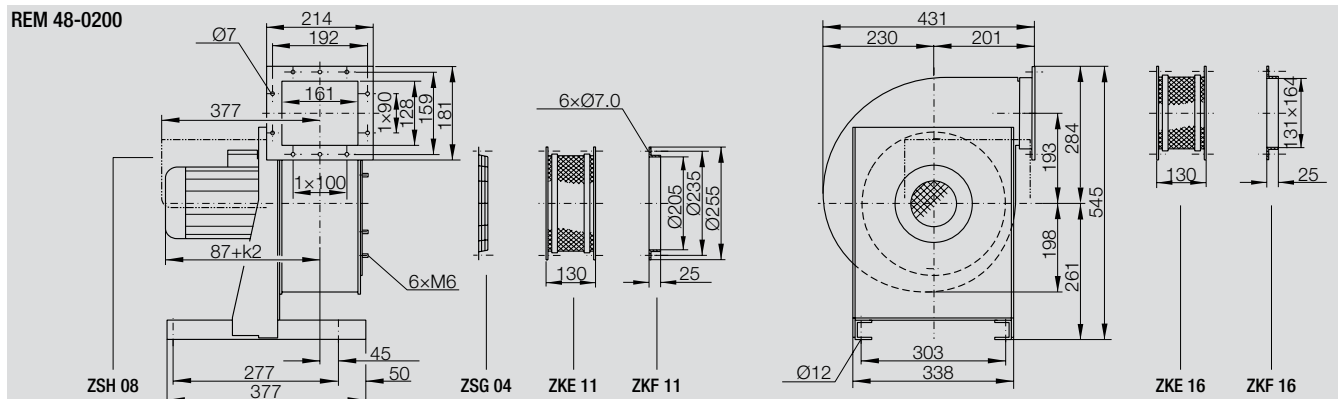

# REM 41-0225 REM 48-0225

## Curves

Density of media **1.2 kg/m<sup>3</sup>**.  
Measured in installation **B** according to **ISO 5801** (ducted).

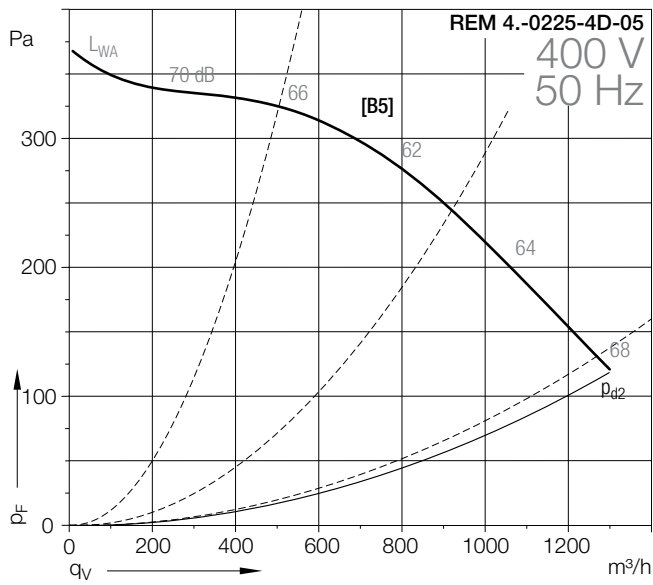
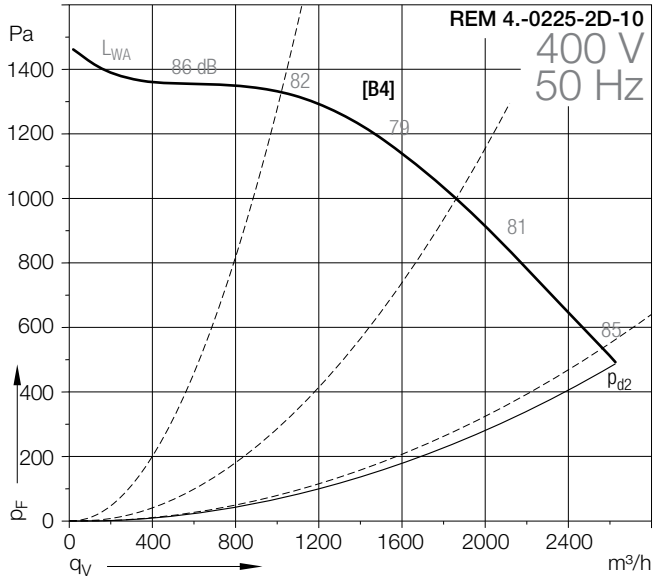
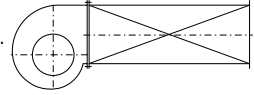



# REM 41-0225

# REM 48-0225

## Technical Data

REM 41-	Curves	Nominal motor power kW	Poles	Motor size	Motor voltage V	Nominal frequency Hz	Connection	Nominal motor current A	Nominal motor speed 1/min	Max. media Temperature °C	Max. volume flow m³/h	Weight kg
0225-2W-10	[B4]	0.75	2	80 M	230/400	50	Δ/Y	2.89/1.67	2805	60	2625	22
0225-4D-05	[B5]	0.18	4	63 M	230/400	50	Δ/Y	1.00/0.58	1350	60	1300	18

REM 48-	Curves	Nominal motor power kW	Poles	Motor size	Motor voltage V	Nominal frequency Hz	Connection	Nominal motor current A	Nominal motor speed 1/min	Max. media Temperature °C	Max. volume flow m³/h	Weight kg
0225-2W-10	[B4]	0.75	2	80 M	230/400	50	Δ/Y	2.89/1.67	2805	60	2625	33
0225-4D-05	[B5]	0.18	4	63 M	230/400	50	Δ/Y	1.00/0.58	1350	60	1300	29

### Dimensions in mm, subject to change.

#### REM 41-0225

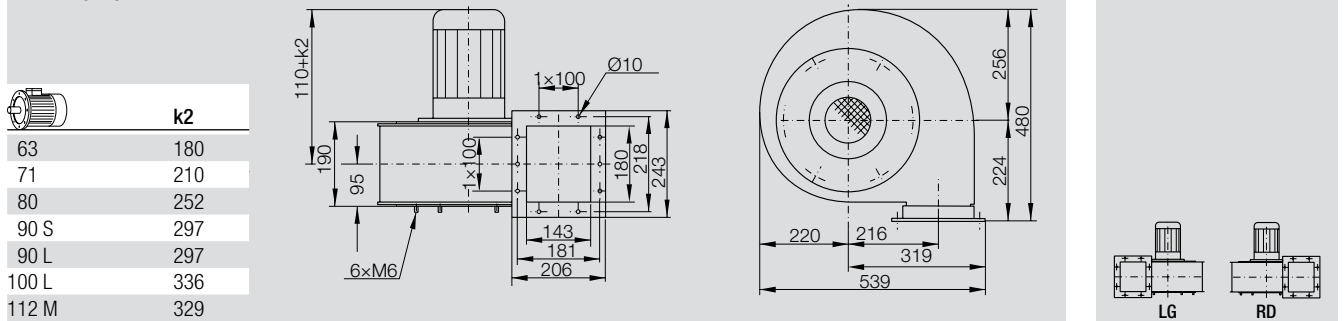

#### REM 48-0225

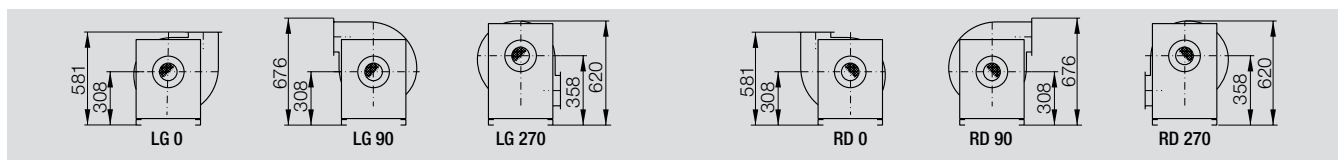
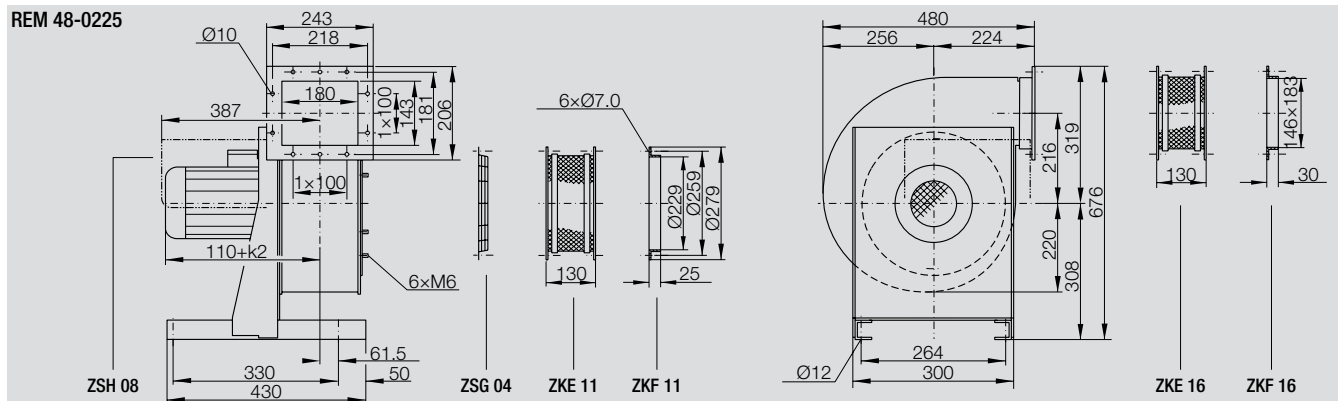

# REM 41-0250 REM 48-0250

## Curves

Density of media **1.2 kg/m<sup>3</sup>**.  
Measured in installation **B** according to **ISO 5801** (ducted).

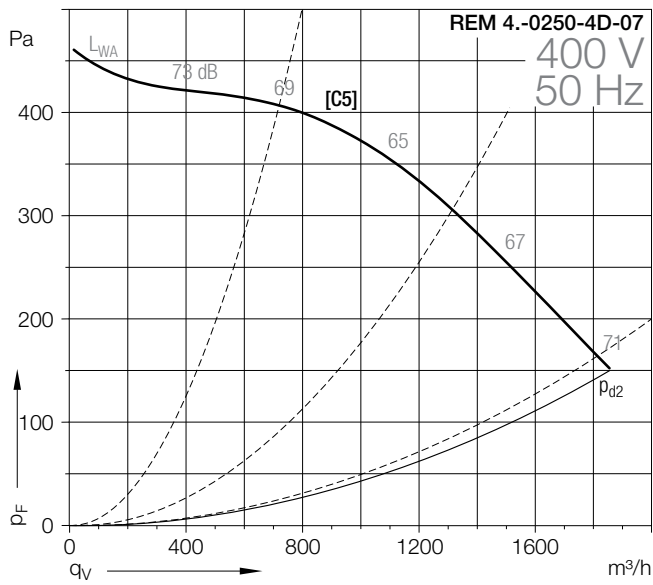
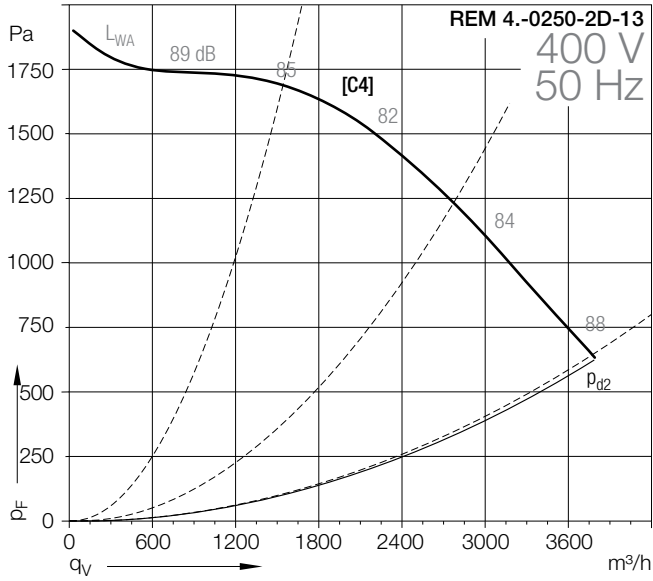
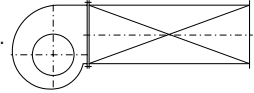

# REM 41-0250 REM 48-0250

## Technical Data

REM 41-	Curves	Nominal motor power kW	Poles	Motor size	Motor voltage V	Nominal frequency Hz	Connection	Nominal motor current A	Nominal motor speed 1/min	Max. media Temperature °C	Max. volume flow m³/h	Weight kg
0250-2W-13	[C4]	1.50	2	90 S	230/400	50	Δ/Y	5.50/3.20	2880	60	3789	34
0250-4D-07	[C5]	0.25	4	71 M	230/400	50	Δ/Y	1.33/0.77	1350	60	1855	27

REM 48-	Curves	Nominal motor power kW	Poles	Motor size	Motor voltage V	Nominal frequency Hz	Connection	Nominal motor current A	Nominal motor speed 1/min	Max. media Temperature °C	Max. volume flow m³/h	Weight kg
0250-2W-13	[C4]	1.50	2	90 S	230/400	50	Δ/Y	5.50/3.20	2860	60	3789	48
0250-4D-07	[C5]	0.25	4	71 M	230/400	50	Δ/Y	1.33/0.77	1350	60	1855	41

### Dimensions in mm, subject to change.

#### REM 41-0250

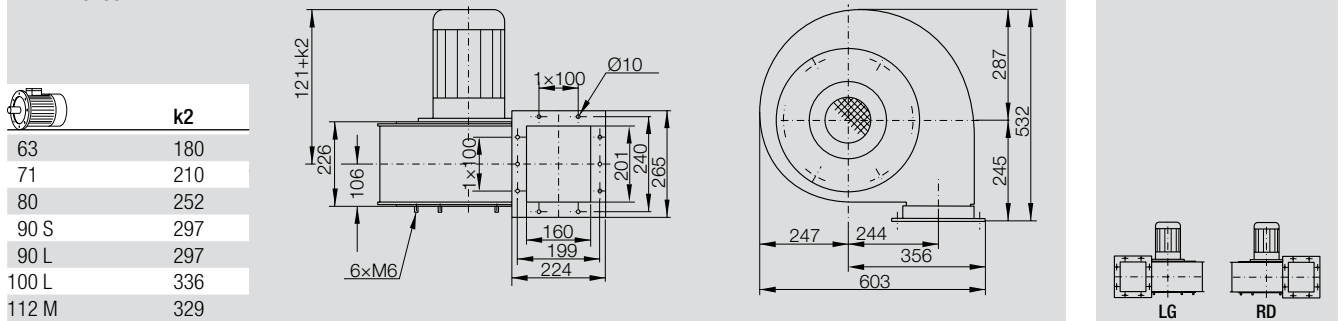

#### REM 48-0250

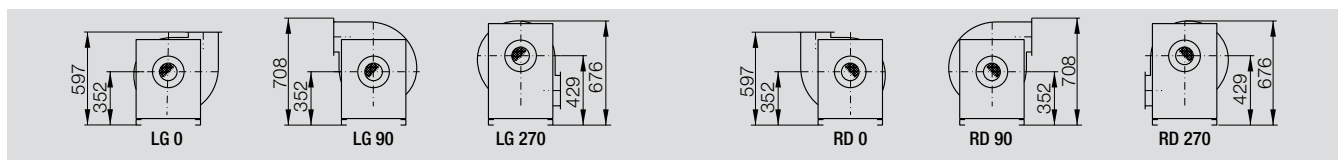
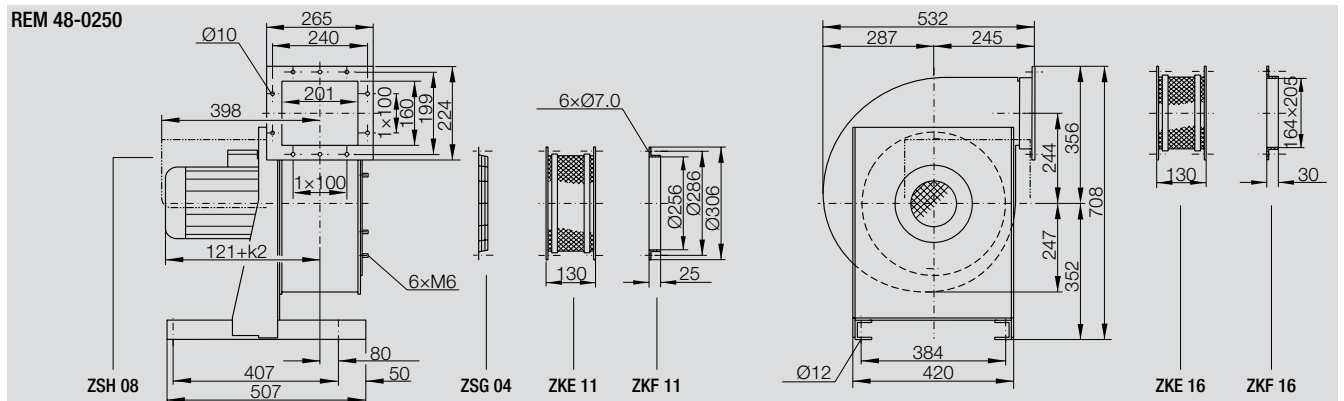

# REM 41-0280 REM 48-0280

## Curves

Density of media **1.2 kg/m<sup>3</sup>**.  
Measured in installation **B** according to **ISO 5801** (ducted).

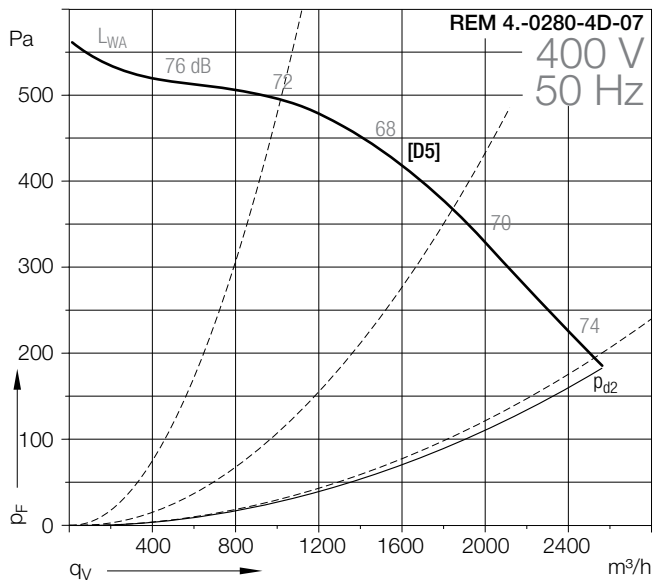
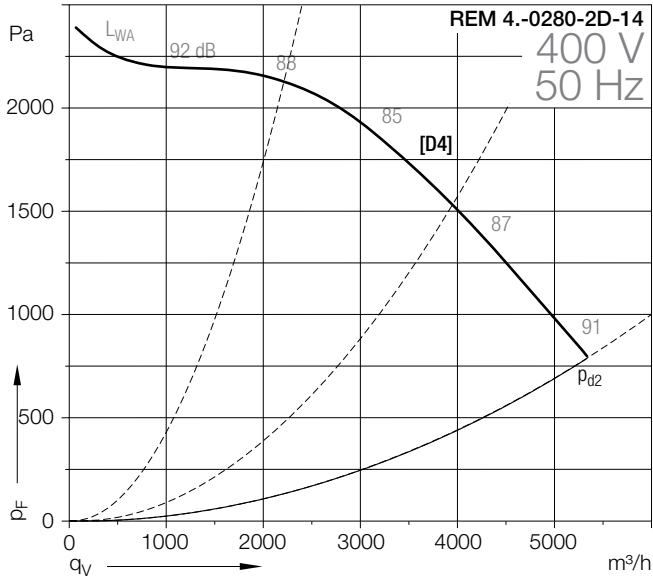
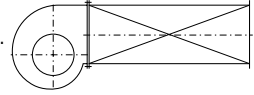

# REM 41-0280

# REM 48-0280

## Technical Data

REM 41-	Curves	Nominal motor power kW	Poles	Motor size	Motor voltage V	Nominal frequency Hz	Connection	Nominal motor current A	Nominal motor speed 1/min	Max. media Temperature °C	Max. volume flow m³/h	Weight kg
0280-2W-14	[D4]	2.20	2	90 L	230/400	50	Δ/Y	7.80/4.50	2880	60	5334	43
0280-4D-07	[D5]	0.25	4	71 M	230/400	50	Δ/Y	1.33/0.77	1350	60	2566	33

REM 48-	Curves	Nominal motor power kW	Poles	Motor size	Motor voltage V	Nominal frequency Hz	Connection	Nominal motor current A	Nominal motor speed 1/min	Max. media Temperature °C	Max. volume flow m³/h	Weight kg
0280-2W-14	[D4]	2.20	2	90 L	230/400	50	Δ/Y	7.80/4.50	2880	60	5334	57
0280-4D-07	[D5]	0.25	4	71 M	230/400	50	Δ/Y	1.33/0.77	1350	60	2566	47

### Dimensions in mm, subject to change.

#### REM 41-0280

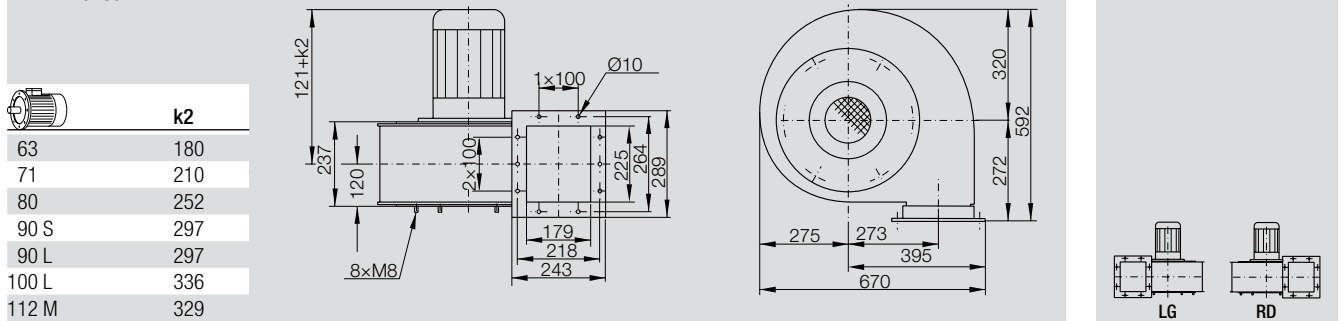

#### REM 48-0280

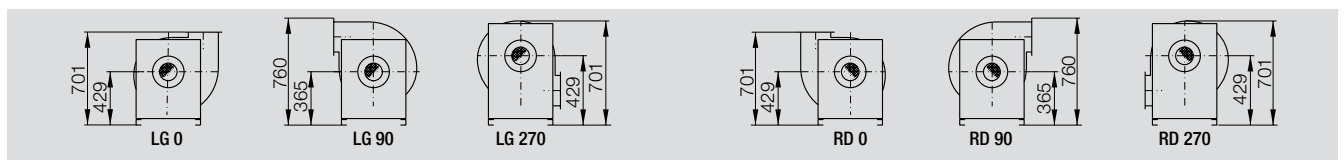
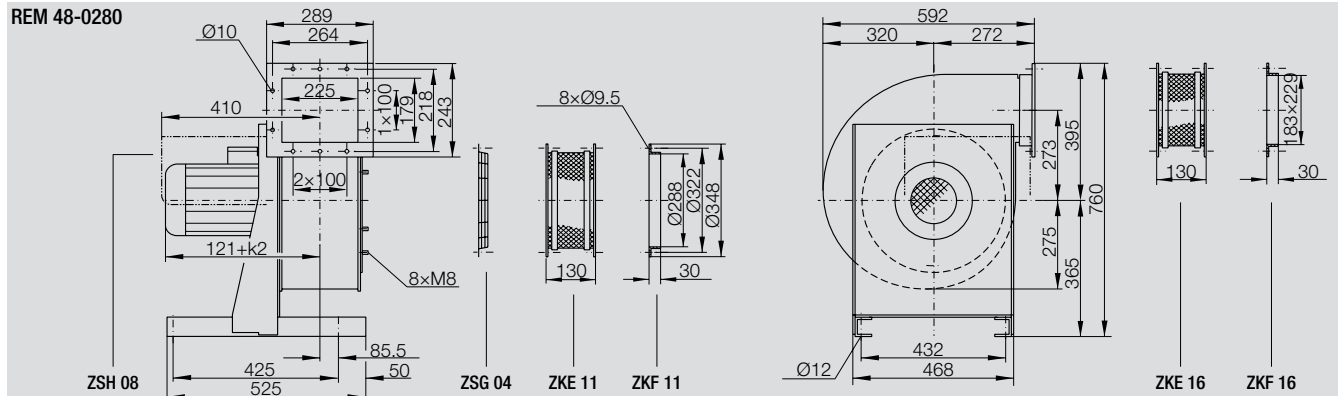

# REM 41-0315 REM 48-0315

## Curves

Density of media **1.2 kg/m<sup>3</sup>**.  
Measured in installation **B** according to **ISO 5801** (ducted).

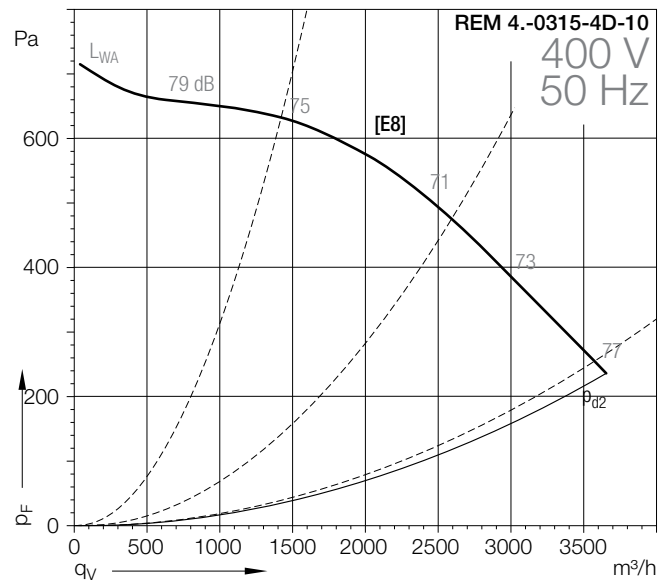
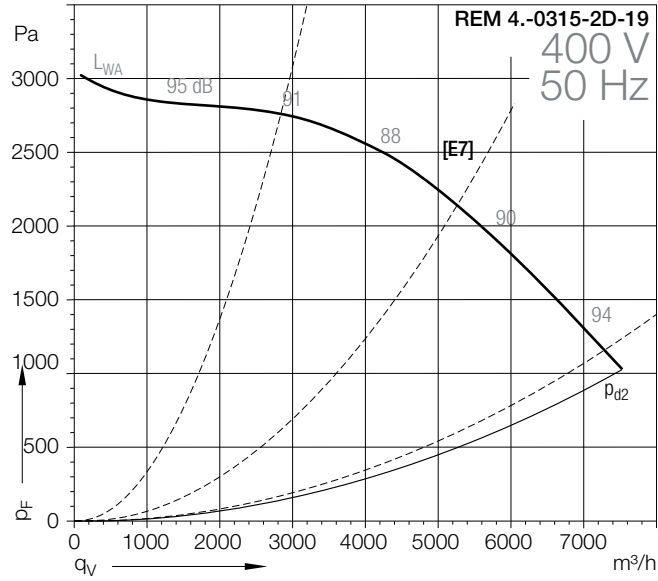
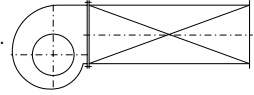

# REM 41-0315

# REM 48-0315

## Technical Data

REM 41-	Curves	Nominal motor power kW	Poles	Motor size	Motor voltage V	Nominal frequency Hz	Connection	Nominal motor current A	Nominal motor speed 1/min	Max. media Temperature °C	Max. volume flow m³/h	Weight kg
0315-2W-19	[E7]	4.00	2	112 M	400	50	△	7.80	2950	60	7520	74
0315-4D-10	[E8]	0.55	4	80 M	230/400	50	△/Y	2.53/1.46	1395	60	3654	42

REM 48-	Curves	Nominal motor power kW	Poles	Motor size	Motor voltage V	Nominal frequency Hz	Connection	Nominal motor current A	Nominal motor speed 1/min	Max. media Temperature °C	Max. volume flow m³/h	Weight kg
0315-2W-19	[E7]	4.00	2	112 M	400	50	△	7.80	2950	60	7520	92
0315-4D-10	[E8]	0.55	4	80 M	230/400	50	△/Y	2.53/1.46	1395	60	3654	60

### Dimensions in mm, subject to change.

#### REM 41-0315

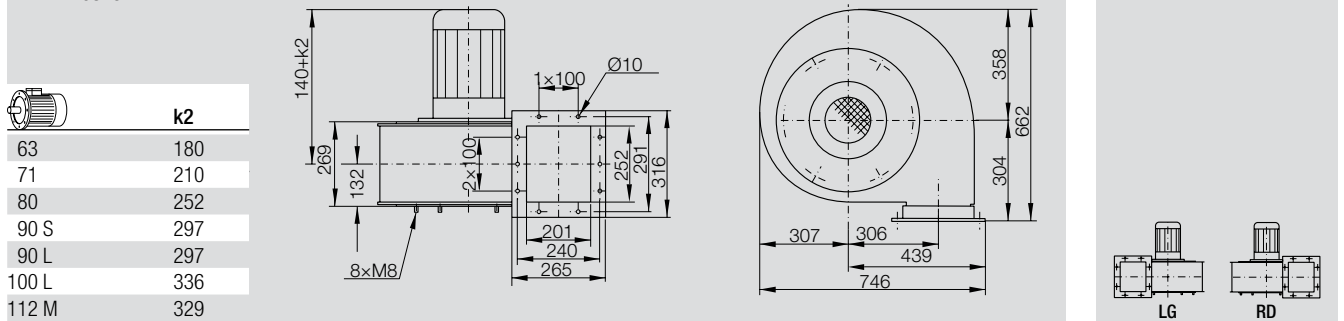

#### REM 48-0315

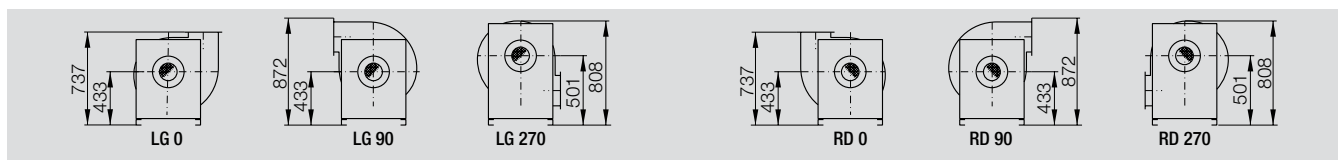
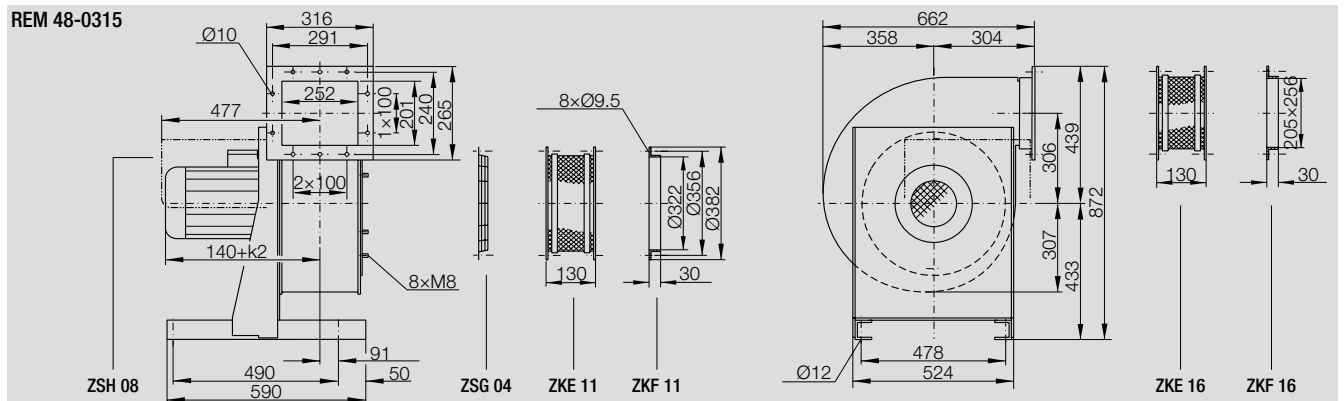

# REM 41-0355 REM 48-0355

## Curves

Density of media **1.2 kg/m<sup>3</sup>**.  
Measured in installation **B** according to **ISO 5801** (ducted).

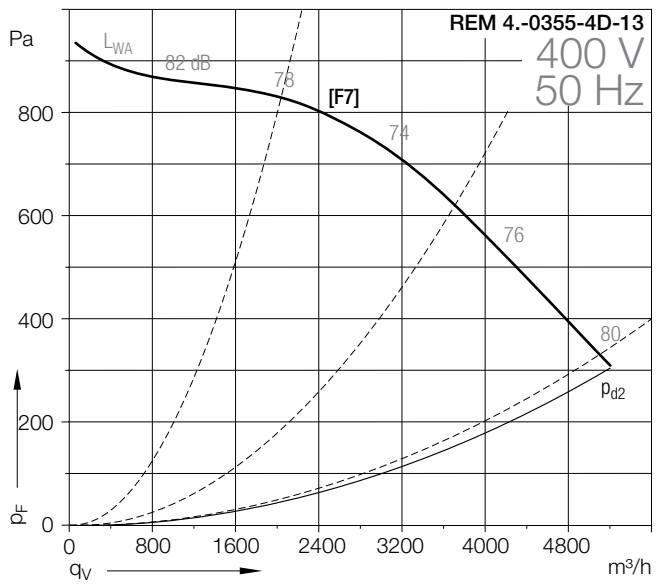
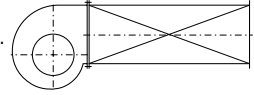



# REM 41-0355

# REM 48-0355

## Technical Data

	Curves	Nominal motor power kW	Poles	Motor size	Motor voltage V	Nominal frequency Hz	Connection	Nominal motor current A	Nominal motor speed 1/min	Max. media Temperature °C	Max. volume flow m³/h	Weight kg
<b>REM 41-</b>												
0355-4W-13	[F7]	1.10	4	90 S	230/400	50	Δ/Y	4.30/2.50	1425	60	5208	54
<b>REM 48-</b>												
0355-4W-13	[F7]	1.10	4	90 S	230/400	50	Δ/Y	4.30/2.50	1425	60	5208	72

**Dimensions** in mm, subject to change.

**REM 41-0355**

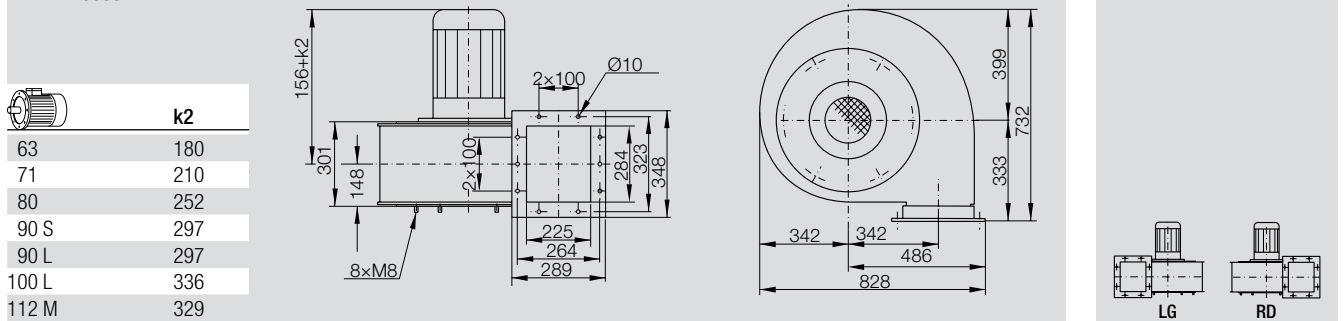

**REM 48-0355**

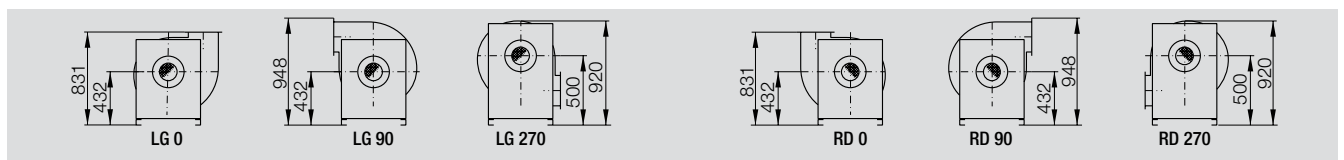
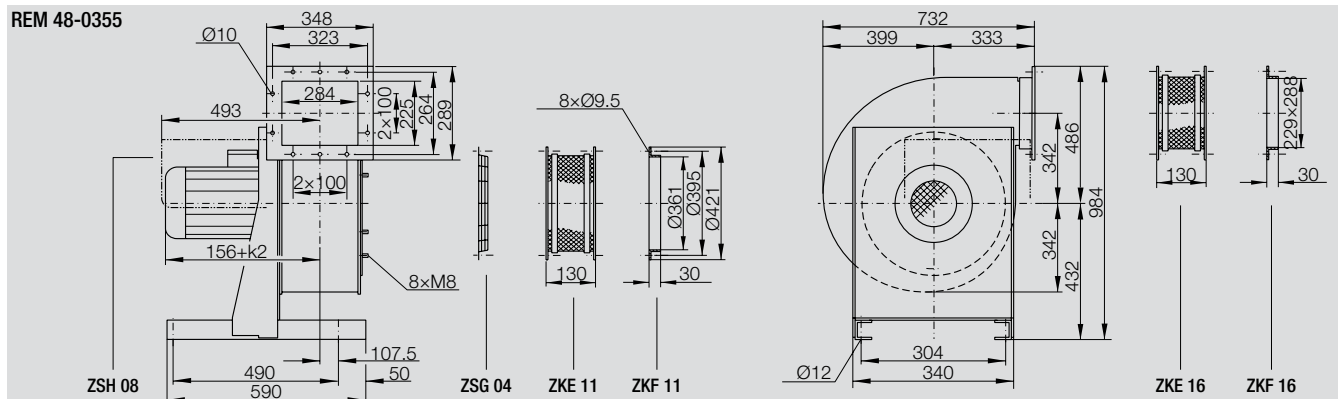

# REM 41-0400 REM 48-0400

## Curves

Density of media **1.2 kg/m<sup>3</sup>**.  
Measured in installation **B** according to **ISO 5801** (ducted).

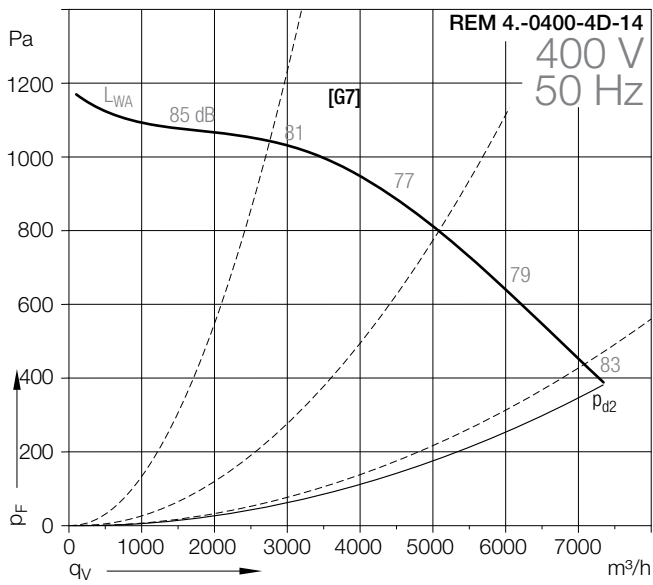
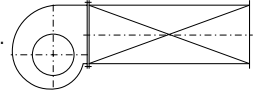

# REM 41-0400

# REM 48-0400

## Technical Data

	Curves	Nominal motor power kW	Poles	Motor size	Motor voltage V	Nominal frequency Hz	Connection	Nominal motor current A	Nominal motor speed 1/min	Max. media Temperature °C	Max. volume flow m³/h	Weight kg
<b>REM 41-</b>												
<b>0400-4W-14</b>	[G7]	1.50	4	90 L	230/400	50	Δ/Y	5.70/3.30	1435	60	7338	69
<b>REM 48-</b>												
<b>0400-4W-14</b>	[G7]	1.50	4	90 L	230/400	50	Δ/Y	5.70/3.30	1435	60	7338	87

**Dimensions** in mm, subject to change.

**REM 41-0400**

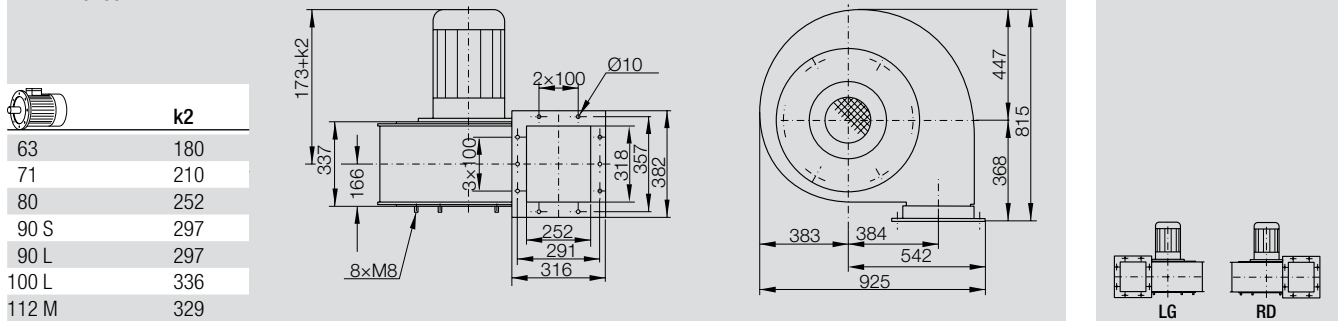

**REM 48-0400**

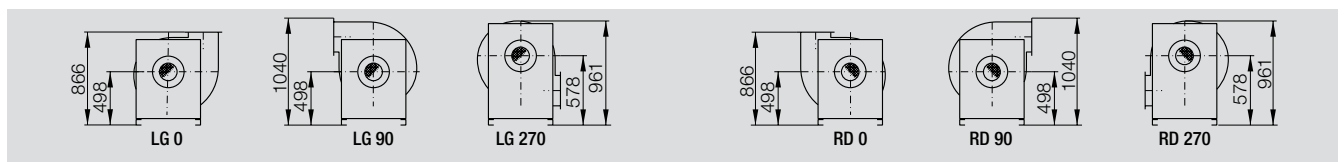
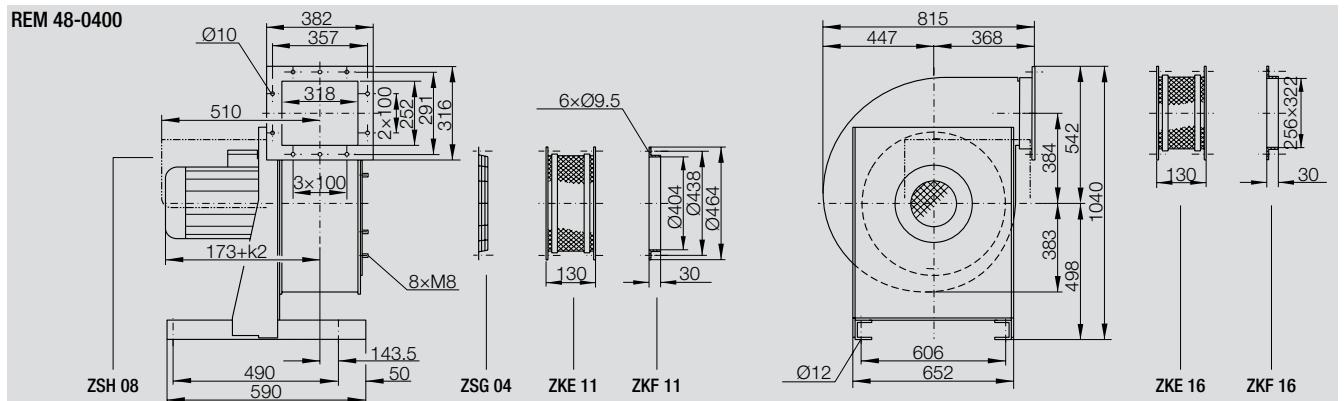

# REM 41-0450 REM 48-0450

## Curves

Density of media **1.2 kg/m<sup>3</sup>**.  
Measured in installation **B** according to **ISO 5801** (ducted).

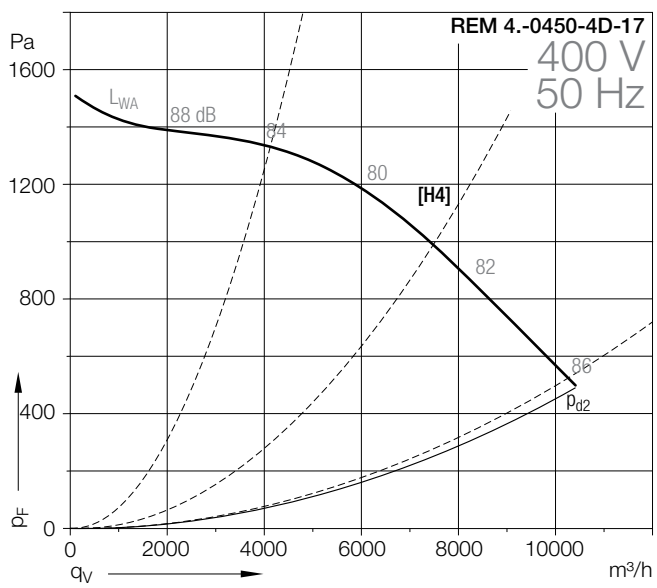
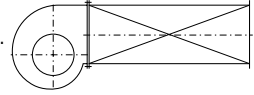

# REM 41-0450 REM 48-0450

## Technical Data

	Curves	Nominal motor power kW	Poles	Motor size	Motor voltage V	Nominal frequency Hz	Connection	Nominal motor current A	Nominal motor speed 1/min	Max. media Temperature °C	Max. volume flow m³/h	Weight kg
<b>REM 41-</b>												
<b>0450-4W-17</b>	[H4]	3.00	4	100 L	230/400	50	Δ/Y	10.70/6.20	1455	60	10418	91
<b>REM 48-</b>												
<b>0450-4W-17</b>	[H4]	3.00	4	100 L	230/400	50	Δ/Y	10.70/6.20	1455	60	10418	113

### Dimensions in mm, subject to change.

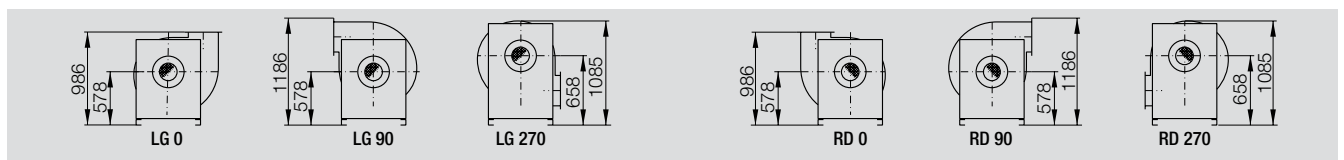
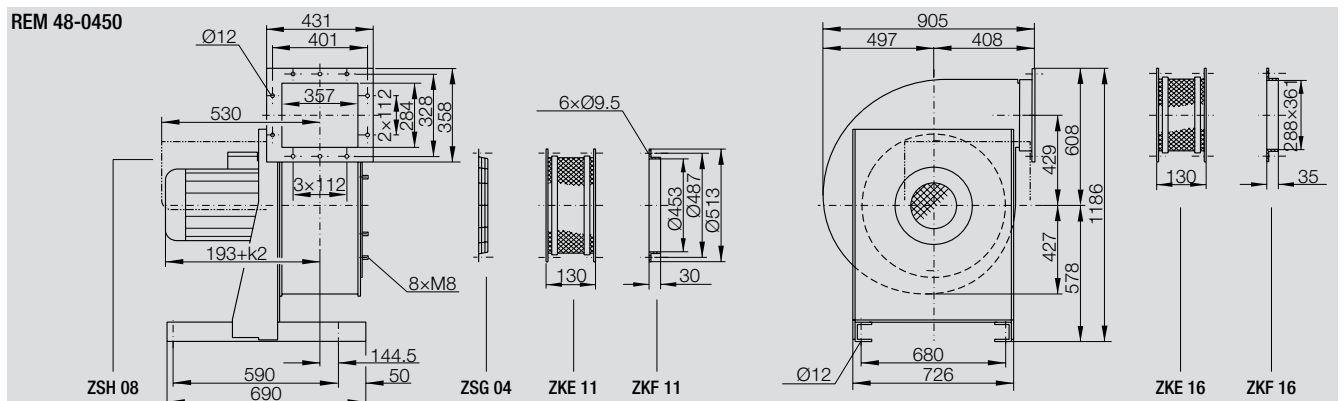
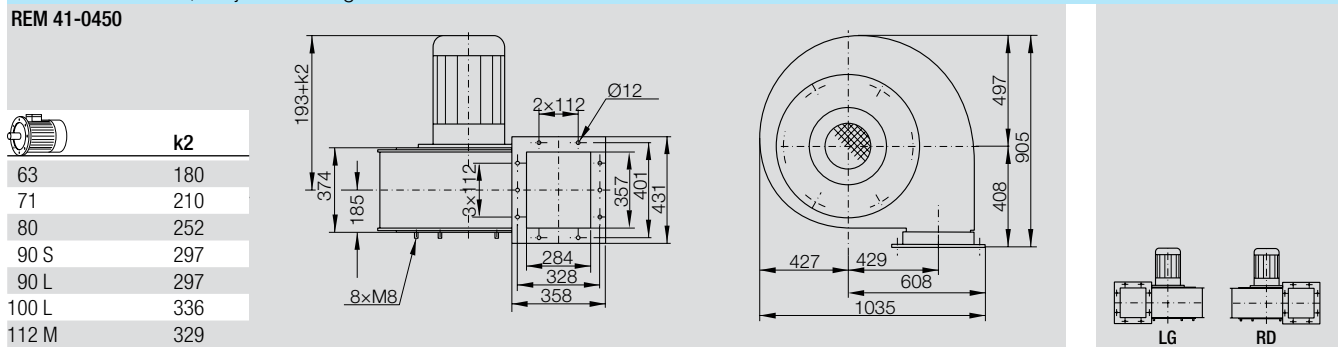

# Technical Data

## Technical Data according to ErP-REGULATION 327/2011/EU

50 Hz REM 10-	Overall efficiency $\eta_e$ [%]	Measure- ment category	Efficiency category	achieved effici- ency grade at optimum energy efficiency "N"	required efficiency grade acc. to ErP since		Speed control (VSD)	Rated motor po- wer at optimum energy efficiency $P_e$ [kW]	Flow rate at op- timum energy efficiency $q_v$ [m <sup>3</sup> /h]	Pressure at op- timum energy efficiency $p_F$ [Pa]	Speed at op- timum energy efficiency $N$ [1/min]	"specific ratio"
					2013	2015						
0200-2D-07	39.1	B	TOTAL	55.8	61	64	without	0.256	702	513	2924	1.005
0225-2D-07	51.2	B	TOTAL	66.5	61	64	without	0.346	987	646	2864	1.006
0250-2D-08	55.0	B	TOTAL	68.4	61	64	without	0.534	1407	752	2860	1.008
0280-2W-11	56.5	B	TOTAL	67.0	61	64	without	0.999	2105	965	2880	1.010
0315-2W-13	62.7	B	TOTAL	71.0	61	64	without	1.596	2826	1274	2892	1.013
0355-2W-16	64.2	B	TOTAL	69.9	61	64	without	2.851	4025	1637	2905	1.016
0400-2W-21	67.9	B	TOTAL	70.8	61	64	without	5.313	5963	2178	2950	1.022
0315-4D-07	46.3	B	TOTAL	63.0	61	64	without	0.259	1393	310	1426	1.003
0355-4D-08	52.2	B	TOTAL	66.8	61	64	without	0.405	1960	388	1407	1.004
0400-4D-10	60.2	B	TOTAL	72.7	61	64	without	0.639	2813	492	1395	1.005
0450-4W-13	63.3	B	TOTAL	73.2	61	64	without	1.154	4074	646	1425	1.006
0500-4W-16	67.1	B	TOTAL	74.2	61	64	without	2.104	5886	863	1455	1.009
0560-4W-19	69.8	B	TOTAL	74.5	61	64	without	3.544	8218	1083	1460	1.011
0630-4W-23	73.2	B	TOTAL	75.3	61	64	without	6.207	12220	1338	1465	1.013
0500-6D-11	57.7	B	TOTAL	70.3	61	64	without	0.631	3742	350	924	1.004
0560-6W-14	65.0	B	TOTAL	75.3	61	64	without	1.042	5337	457	944	1.005
0630-6W-19	68.8	B	TOTAL	76.4	61	64	without	1.887	7977	586	965	1.006

## Technical Data according to ErP-REGULATION 327/2011/EU

60 Hz REM 10-	Overall efficiency $\eta_e$ [%]	Measure- ment category	Efficiency category	achieved effici- ency grade at optimum energy efficiency "N"	required efficiency grade acc. to ErP since		Speed control (VSD)	Rated motor po- wer at optimum energy efficiency $P_e$ [kW]	Flow rate at op- timum energy efficiency $q_v$ [m <sup>3</sup> /h]	Pressure at op- timum energy efficiency $p_F$ [Pa]	Speed at op- timum energy efficiency $N$ [1/min]	"specific ratio"
					2013	2015						
0200-2D-07-60	47.0	B	TOTAL	62.3	61	64	without	0.348	827	712	3444	1.007
0225-2D-07-60	48.3	B	TOTAL	61.3	61	64	without	0.574	1145	871	3325	1.009
0250-2W-10-60	59.4	B	TOTAL	70.5	61	64	without	0.878	1702	1104	3490	1.011
0280-2W-11-60	60.0	B	TOTAL	68.4	61	64	without	1.585	2505	1367	3460	1.014
0315-2W-14-60	64.3	B	TOTAL	70.2	61	64	without	2.750	3415	1863	3497	1.019
0355-2W-19-60	67.7	B	TOTAL	70.9	61	64	without	4.868	4897	2421	3550	1.024
0400-2W-22-60	71.7	B	TOTAL	72.3	61	64	without	8.714	7159	3141	3550	1.031
0315-4D-07-60	49.4	B	TOTAL	64.3	61	64	without	0.379	1616	417	1654	1.004
0355-4D-10-60	54.5	B	TOTAL	66.6	61	64	without	0.695	2381	572	1709	1.006
0400-4W-13-60	66.3	B	TOTAL	76.3	61	64	without	1.128	3528	763	1740	1.008
0450-4W-14-60	67.7	B	TOTAL	75.3	61	64	without	1.917	4937	947	1740	1.009
0500-4W-17-60	70.9	B	TOTAL	76.0	61	64	without	3.302	6963	1211	1755	1.012
0560-4W-21-60	72.7	B	TOTAL	75.0	61	64	without	5.956	9911	1572	1765	1.016
0500-6W-13-60	62.4	B	TOTAL	72.8	61	64	without	1.008	4490	504	1130	1.005
0560-6W-16-60	65.8	B	TOTAL	73.8	61	64	without	1.752	6375	651	1170	1.007
0630-6W-21-60	69.8	B	TOTAL	75.0	61	64	without	3.185	9535	839	1170	1.008

# Technical Data

## Technical Data according to ErP-REGULATION 327/2011/EU

REM 40-	Overall efficiency $\eta_e$ [%]	Measure-ment category	Efficiency category	achieved efficiency grade at optimum energy efficiency "N"	required efficiency grade acc. to ErP since		Speed control (VSD)	Rated motor power at optimum energy efficiency $P_e$ [kW]	Flow rate at optimum energy efficiency $q_v$ [m³/h]	Pressure at optimum energy efficiency $p_F$ [Pa]	Speed at optimum energy efficiency $N$ [1/min]	"specific ratio"
					2013	2015						
0200-2D-07	53.5	B	TOTAL	66.8	61	64	without	0.539	1215	853	2740	1.009
0225-2W-10	63.5	B	TOTAL	74.9	61	64	without	0.810	1706	1085	2805	1.011
0250-2W-13	66.7	B	TOTAL	75.6	61	64	without	1.423	2464	1386	2885	1.014
0280-2W-14	69.1	B	TOTAL	75.5	61	64	without	2.439	3469	1748	2890	1.017
0315-2W-19	71.2	B	TOTAL	75.0	61	64	without	4.393	5075	2219	2950	1.022
0225-4D-05	47.8	B	TOTAL	67.6	61	64	without	0.130	845	265	1350	1.003
0250-4D-07	50.8	B	TOTAL	68.2	61	64	without	0.219	1206	332	1350	1.003
0280-4D-07	51.4	B	TOTAL	66.5	61	64	without	0.365	1669	405	1350	1.004
0315-4D-10	57.6	B	TOTAL	70.5	61	64	without	0.593	2377	517	1395	1.005
0355-4W-13	68.4	B	TOTAL	79.2	61	64	without	0.932	3385	678	1425	1.007
0400-4W-14	70.4	B	TOTAL	78.8	61	64	without	1.594	4773	846	1435	1.008
0450-4W-17	73.5	B	TOTAL	79.4	61	64	without	2.789	6772	1090	1455	1.011

**REM 11-0200/-0630**  
**REM 13-0200/-0630**

**REM 18-0200/-0630**  
**REM 19-0200/-0630**

**Specifications**

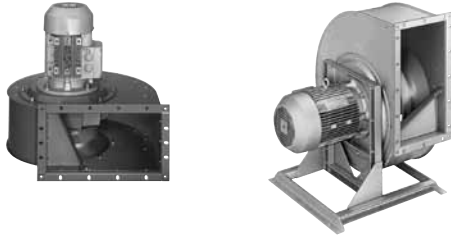

**High performance centrifugal fans REM rotavent**

single inlet, direct driven.  
 Lap-jointed scroll housing made from galvanised steel sheet - Range REM11/REM18 **or** welded and coated - Range REM13/REM19.  
 Without pedestal for vertical or horizontal mounting - Range REM11/REM13 **or** with pedestal for horizontal mounting - Range REM18/REM19.  
 Suitable for conveying medium temperatures from -20 °C to +60 °C.  
 At discharge with integrated flange acc. to DIN 24159-3, at intake with possibility to connect with flange acc. to DIN 24155-2.  
 Radial impeller with backward curved aerofoil blades, welded and coated.  
 B5 motor mounted outside the airstream. Impeller balanced in according to DIN ISO 1940, completely maintenance free. Motor equipped with PTC Thermistors as a standard (except motors in explosion proof execution according to ATEX 94/9/ EC).  
 Three phase 400 V, 50 Hz, single speed.

**Fan data**

Fan type	TEM	
Volume flow	$q_V$	m <sup>3</sup> /h
Total pressure increase	$p_F$	Pa
Air density at fan inlet	$\rho_1$	kg/m <sup>3</sup>
Air temperature	t	°C
Speed	N	1/min
Nominal motor power	$P_N$	kW
Voltage	U	V
Frequency	f	Hz
Sound power level (A weighted)	$L_{WA}$	dB
Weight	m	kg

**Fittings / Accessories**

- ▶ Drain plug R1/2"
- ▶ Inspection door
- ▶ Corrosion protection S40
- ▶ Impeller-blades continuously welded
- ▶ Scroll inside continuously welded (REM13/REM19)
- ▶ Scroll inside and outside continuously welded (REM13/REM19)
- ▶ Nuts and bolts from stainless steel
  
- ▶ Inlet flange
- ▶ Inlet flex (with flexible sleeve)
- ▶ Discharge flange
- ▶ Discharge flex (with flexible sleeve)
- ▶ Inlet protection guard
- ▶ Discharge protection guard
- ▶ Anti-vibration mounts (REM18/19)
  
- ▶ Isolator
- ▶ Motor protection unit



# REM 41-0200/-0450 REM 48-0200/-0450

## Specifications



### High performance centrifugal fans REM 40

single inlet with direct drive. Lap-jointed scroll housing made from galvanised steel sheet, without pedestal for vertical or horizontal mounting - Range REM41 **or** with pedestal for horizontal mounting - Range REM48.  
 Suitable for conveying medium temperatures from -20 °C to +60 °C.  
 At discharge with integrated flange acc. to DIN 24159-3, at intake with possibility to connect with flange acc. to DIN 24155-2.  
 Radial impeller with backward curved blades, welded and coated. B5 motor mounted outside the airstream. Impeller statically and dynamically balanced according to DIN ISO 1940, completely maintenance free.  
 Motor equipped with PTC Thermistors as a standard.  
 Three phase 400 V, 50 Hz, single speed.

## Fan data

Fan type	TEM		
Volume flow	$q_V$		m <sup>3</sup> /h
Total pressure increase	$p_F$		Pa
Air density at fan inlet	$\rho_1$		kg/m <sup>3</sup>
Air temperature	t		°C
Speed	N		1/min
Nominal motor power	$P_N$		kW
Voltage	U		V
Frequency	f		Hz
Sound power level (A weighted)	$L_{WA}$		dB
Weight	m		kg

## Fittings / Accessories

- ▶ Drain plug R1/2"
- ▶ Inspection door
  
- ▶ Inlet flange
- ▶ Inlet flex (with flexible sleeve)
- ▶ Discharge flange
- ▶ Discharge flex (with flexible sleeve)
- ▶ Inlet protection guard
- ▶ Anti-vibration mounts (REM48)
  
- ▶ Isolator
- ▶ Motor protection unit

# Accessories

## Accessories

All options and accessories must be specified separately. Please take the technical data and dimensions from the corresponding page of the catalogue.

### Drain Plug



If the fan is installed outside, or if conveying a medium containing humidity, condensation of water may accumulate inside the fan scroll. For extraction of this water a condense water drain has to be installed at the lowest point of the scroll. The drain will be provided with a thread R1/2" for connecting it to a piping. At order please indicate the required casing position.

### Inspection Door



For the purposes of maintenance and cleaning there is an opening, which can be securely closed by means of an access door, in the fan casing. As it can only be opened with a tool, the access door complies with safety and accident prevention regulations. Additional securing with locking bars can be supplied on request. The site and orientation of the inspection opening depends on the casing position. The position should be specified when ordering according to the following diagram: e.g. Access door, Pos. 2.

#### Inspection Door Positions

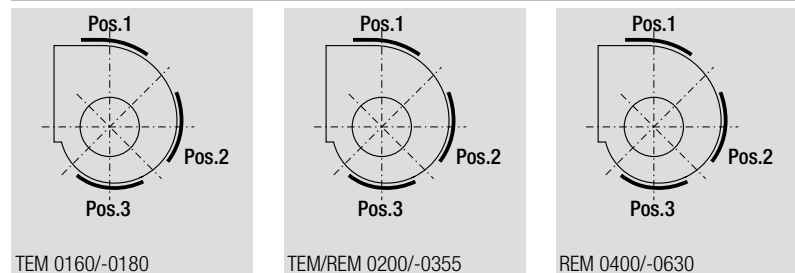

**Dimensions** in mm, subject to change.

TEM ..-		TEM ..- / REM ..-		REM ..-	
<b>0160/-0180</b>	60 × 210	<b>0200/-0225</b>	60 × 210	<b>0315/-0560</b>	210 × 210
		<b>0250/-0355</b>	110 × 210	<b>0630</b>	310 × 310

### Motor protection hood



Picture may differ from original product.

Motor protection hood, made of galvanised sheet steel, for additional motor protection against weather if the fan is installed outside.

### Corrosion Protection Systems

Nicotra Gebhardt fans are treated with high quality corrosion protection as standard. Under extreme operating conditions, however, additional corrosion protection is advisable.

#### Corrosion protection - Class S40

Degreasing, ironphosphating

► **Powder coating** - Layer thickness  $\geq 40 \mu\text{m}$ , Colour RAL 7039

► **Wet lacquering** - Layer thickness  $\geq 40 \mu\text{m}$  (primer + lacquer finish), Colour RAL 7039

# Accessories

## Continuously welded impeller blades REM 10



Impeller blades can be continuously welded in order to increase the corrosion resistance when conveying a humid or slightly aggressive medium. The continuous welding has no influence on the material resistance or on the max. tip speed.

## Continuously welded scroll REM 10



The casing can be continuously welded in order to increase the corrosion resistance when conveying a humid or slightly aggressive medium. By continuous welding the casing is provided with additional impermeability.

- ▶ **GEH 01** - Casing inside continuously welded
- ▶ **GEH 02** - Casing inside and outside continuously welded

## Stainless steel nuts and bolts REM 10



For applications where there is an increased risk of corrosion, the connecting elements of the fan can be ordered made of stainless steel.

## Protection guards



The fans are designed for installation in equipment and as standard are not equipped with protective guards.

**They should not be put into operation before all protective devices are fitted and connected!**

Protective measures must be carried out as set out in DIN EN ISO 12100 "Safety of machinery - Basic concepts, general principles for design". If the application of the fan allows free access to the inlet and discharge apertures, safety devices must be put in place on the fan in accordance with DIN EN ISO 13857! Suitable safety guards are available as an optional extra.

## Flanges and Flexible Connections



Flanges and flexible connection pieces are available for the inlet and discharge sides.

# Accessories

## Anti Vibration Mounts

Anti Vibration Mounts (AVM) are designed to prevent noise and vibrations being transmitted through the base of the fan. AVMs should be mounted beneath the fan base frame so the weight and spring deflections are evenly distributed.

They should not be mounted symmetrically around the centre of gravity of the system when idle, because a counter force is induced into the system by the pressure created by the working fan.

It is difficult for the manufacturer to establish the position of the AV mounts to suit all types of application.

Vibration and noise insulation can also be improved by ensuring that the fan is connected to its external environment by a flexible coupling.

► **Rubber buffers** - for both vibration and noise insulation at fan speeds above 1400 rpm or 850 rpm

► **Rubber buffers** - for noise insulation only at fan speeds under 800 rpm or 1700 rpm

## Anti Vibration Rubber Pads



Anti Vibration Rubber Pads

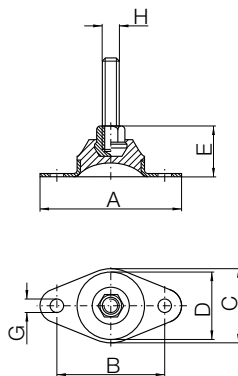

ZBD	ZBD	A	B	C	D	E	G	H
21-6035A*	21-6035C*	60	45	35	30	20	5	M6
21-6065A*	21-6065C*	60	45	35	30	20	6	M6
21-5935A*	21-5935C*	90	70	50	45	32	9	M10
21-5950A*	21-5950C*	90	70	50	45	32	9	M10

\* A = for U-profile; C = for CC-profile

## Anti Vibration Rubber Buffers



Anti Vibration Rubber Buffers

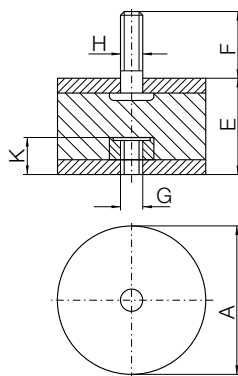

ZBD	ZBD	A	E	F	G	H	K
01-0405A*	01-0405C*	20	25	16	M6	M6	6.5
03-0503A*	03-0503C*	25	15	11	M6	M6	6.5
01-0504A*	01-0504C*	25	20	11	M6	M6	6.5
03-0806A*	03-0806C*	40	30	21	M8	M8	9.5
03-1007A*	03-1007C*	50	34	26.5	M10	M10	10.5
03-1510A*	03-1510C*	75	50	39	M12	M12	12.5
02-2008A*	02-2008C*	100	40	44	M16	M16	16.5

\* A = for U-profile; C = for CC-profile

# Accessories

## Anti Vibration Mounts - Assignment



TEM 08-	ZBD	TEM 08-	ZBD	TEM 08-	ZBD
0160-2D-08	01-0506 (4x)	0160-2D-08-60	01-0506 (4x)	0160-2X-08-3G	01-0506 (4x)
0160-4D-05	03-0503 (4x)	0160-4D-05-60	03-0503 (4x)	0160-4X-05-3G	03-0503 (4x)
0180-2D-11	01-0506 (4x)	0180-2D-11-60	01-0506 (4x)	0180-2X-11-3G	01-0506 (4x)
0180-4D-05	03-0503 (4x)	0180-2D-10-60	01-0506 (4x)	0180-4X-05-3G	03-0503 (4x)
0200-2D-14	01-0606 (4x)	0180-4D-05-60	03-0503 (4x)	0200-2X-14-3G	01-0606 (4x)
0200-4D-08	03-0503 (4x)	0200-2D-14-60	01-0606 (4x)	0200-4X-08-3G	03-0503 (4x)
0225-2D-19	01-0606 (2x)	0200-2D-11-60	01-0506 (4x)	0225-2X-19-3G	01-0606 (2x)
	01-0806 (2x)	0200-4D-08-60	03-0503 (4x)		01-0806 (2x)
0225-2D-14	01-0606 (4x)	0225-2D-19-60	01-0606 (2x)	0225-4X-11-3G	01-0506 (4x)
0225-4D-11	01-0506 (4x)		01-0806 (2x)	0250-2X-19-3G	01-0606 (2x)
0250-2D-19	01-0606 (2x)	0225-2D-14-60	01-0606 (4x)		01-0806 (2x)
	01-0806 (2x)	0225-4D-11-60	01-0506 (4x)	0250-4X-13-3G	01-0506 (4x)
0250-2D-14	01-0506 (4x)	0250-4D-13-60	01-0506 (4x)	0280-4X-16-3G	01-0506 (2x)
0250-4D-13	01-0506 (4x)	0250-4D-10-60	01-0506 (4x)		01-0606 (2x)
0250-4D-11	01-0506 (4x)	0250-6D-08-60	03-0806 (4x)	0315-4X-19-3G	01-0606 (2x)
0250-6D-08	03-0806 (4x)	0280-4D-16-60	01-0506 (2x)		01-0806 (2x)
0280-4D-16	01-0506 (2x)		01-0606 (2x)	0355-4X-19-3G	01-0606 (4x)
	01-0606 (2x)	0280-4D-13-60	01-0506 (4x)		
0280-4D-13	01-0506 (4x)	0280-6D-11-60	03-0806 (4x)		
0280-6D-11	01-0806 (4x)	0315-4D-19-60	01-0606 (2x)		
0315-4D-19	01-0606 (2x)		01-0806 (2x)		
	01-0806 (2x)	0315-4D-16-60	01-0606 (4x)		
0315-4D-16	01-0606 (4x)	0315-4D-14-60	01-0506 (4x)		
0315-6D-14	03-0806 (4x)	0315-6D-14-60	03-0806 (4x)		
0355-4D-19	01-0606 (4x)	0355-4D-19-60	01-0606 (4x)		
0355-4D-16	01-0606 (4x)	0355-4D-17-60	01-0606 (4x)		
0355-6D-19	03-0806 (4x)	0355-4D-16-60	01-0606 (4x)		
		0355-6D-19-60	03-0806 (4x)		

## Anti Vibration Mounts - Assignment

REM 18-/19-	ZBD (4x)	REM 18-/19-	ZBD (4x)	REM 18-/19-	ZBD (4x)
0200-2D-07	01-0506	0200-2D-07-60	01-0506	0200-2X-07-2G	01-0506
0225-2D-07	01-0506	0225-2D-07-60	01-0506	0225-2X-07-2G	01-0506
0250-2D-08	01-0506	0250-2D-10-60	01-0506	0250-2X-08-2G	01-0506
0280-2D-11	01-0506	0280-2D-11-60	01-0506	0280-2X-11-2G	01-0506
0315-2D-13	01-0506	0315-2D-14-60	01-0506	0315-2X-14-2G	01-0506
0315-4D-07	01-0506	0315-4D-07-60	01-0506	0315-4X-07-2G	01-0506
0355-2D-16	01-0806	0355-2D-19-60	01-0606	0355-2X-19-2G	01-0606
0355-4D-08	01-0506	0355-4D-10-60	01-0606	0355-4X-08-2G	01-0506

## Anti Vibration Mounts - Assignment

REM 18-/19-	ZBD (2x)	REM 18-/19-	ZBD (2x)	REM 18-/19-	ZBD (2x)
0400-4D-10	01-0606-C 01-0806-C	0400-4D-13-60	01-0606-C 01-0806-C	0400-4X-11-2G	01-0606-C 01-0806-C
0450-4D-13	01-0606-C 01-0806-C	0450-4D-14-60	01-0606-C 01-0806-C	0450-4X-13-2G	01-0606-C 01-0806-C
0500-4D-16	01-0806-C 01-0806-C	0500-4D-17-60	01-0806-C 01-0806-C	0500-4X-16-2G	01-0806-C 01-0806-C
0500-6D-11	01-0606-C 01-0806-C	0500-6D-13-60	01-0606-C 01-0806-C	0560-4X-19-2G	01-1010-C 01-1010-C
0560-4D-19	01-1010-C 01-1010-C	0560-4D-21-60	01-1010-C 01-1010-C		
0560-6D-14	01-1010-C 01-1010-C	0560-6D-16-60	01-1010-C 01-1010-C		
0630-6D-19	01-1010-C 01-1010-C	0630-6D-21-60	01-1010-C 01-1010-C		

# Accessories

## Isolator - Assignment



Isolator ESH 21 ( $\geq 5.5$  kW)

TEM 01-/08-	ESH 21-	TEM 01-/08-	ESH 21-	TEM 01-/08-	ESH 21-
0160-2D-08	0030-32	0160-2D-08-60	–	0160-2X-08-3G	–
0160-4D-05	0030-32	0160-4D-05-60	–	0160-4X-05-3G	–
0180-2D-11	0030-32	0180-2D-11-60	–	0180-2X-11-3G	–
0180-4D-05	0030-32	0180-2D-10-60	–	0180-4X-05-3G	–
0200-2D-14	0030-32	0180-4D-05-60	–	0200-2X-14-3G	–
0200-4D-08	0030-32	0200-2D-14-60	–	0200-4X-08-3G	–
0225-2D-19	0075-62	0200-2D-11-60	–	0225-2X-19-3G	–
0225-2D-14	0030-32	0200-4D-08-60	–	0225-4X-11-3G	–
0225-4D-11	0030-32	0225-2D-19-60	0075-62	0250-2X-19-3G	–
0250-2D-19	0075-62	0225-2D-14-60	–	0250-4X-13-3G	–
0250-2D-14	0030-32	0225-4D-11-60	–	0280-4X-16-3G	–
0250-4D-13	0030-32	0250-4D-13-60	–	0315-4X-19-3G	–
0250-4D-11	0030-32	0250-4D-10-60	–	0355-4X-19-3G	–
0250-6D-08	0030-32	0250-6D-08-60	–		
0280-4D-16	0030-32	0280-4D-16-60	–		
0280-4D-13	0030-32	0280-4D-13-60	–		
0280-6D-11	0030-32	0280-6D-11-60	–		
0315-4D-19	0075-62	0315-4D-19-60	0075-62		
0315-4D-16	0030-32	0315-4D-16-60	–		
0315-6D-14	0030-32	0315-4D-14-60	–		
0355-4D-19	0075-62	0315-6D-14-60	–		
0355-4D-16	0030-32	0355-4D-19-60	0075-62		
0355-6D-19	0030-32	0355-4D-17-60	0075-62		
		0355-4D-16-60	–		
		0355-6D-19-60	–		

# Accessories

## Isolator - Assignment



REM 11-/13-/18-/19-	ESH 21-	REM 11-/13-/18-/19-	ESH 21-	REM 11-/13-/18-/19-	ESH 21-
0200-2D-07	0030-32	0200-2D-07-60	-	0200-2X-07-2G	-
0225-2D-07	0030-32	0225-2D-07-60	-	0225-2X-07-2G	-
0250-2D-08	0030-32	0250-2D-10-60	-	0250-2X-08-2G	-
0280-2D-11	0030-32	0280-2D-11-60	-	0280-2X-11-2G	-
0315-2D-13	0030-32	0315-2D-14-60	-	0315-2X-14-2G	-
0315-4D-07	0030-32	0315-4D-07-60	-	0315-4X-07-2G	-
0355-2D-16	0030-32	0355-2D-19-60	0075-62	0355-2X-19-2G	-
0355-4D-08	0030-32	0355-4D-10-60	-	0355-4X-08-2G	-
0400-2D-21	0075-62	0400-2D-22-60	0075-62	0400-2X-22-2G	-
0400-4D-10	0030-32	0400-4D-13-60	-	0400-4X-11-2G	-
0450-4D-13	0030-32	0450-4D-14-60	-	0450-4X-13-2G	-
0500-4D-16	0030-32	0500-4D-17-60	0075-62	0500-4X-16-2G	-
0500-6D-11	0030-32	0500-6D-13-60	-	0560-4X-19-2G	-
0560-4D-19	0075-62	0560-4D-21-60	0075-62	0630-4X-23-2G	-
0560-6D-14	0030-32	0560-6D-16-60	-		
0630-4D-23	0075-62	0630-6D-21-60	0075-62		
0630-6D-19	0030-32				

## Isolator - Assignment

REM 41-/48-	ESH 21-	REM 41-/48-	ESH 21-	REM 41-/48-	ESH 21-
0200-2D-07	0030-32	0250-2D-13	0030-32	0315-2D-19	0075-62
0200-4D-05	0030-32	0250-4D-07	0030-32	0315-4D-10	0030-32
0225-2D-10	0030-32	0280-2D-14	0030-32	0355-4D-12	0030-32
0225-4D-05	0030-32	0280-4D-07	0030-32	0400-4D-14	0030-32
				0450-4D-17	0055-32

# Accessories

## Frequency converter



### Design

Frequency inverter with variable output voltage and frequency, specially designed for the operation of centrifugal fans with induction motors. Due to the use of modern power semiconductors it is possible to achieve a speed of revolution with high efficiency. Switching frequencies up to 16 kHz can be set with all types. If the highest switching frequencies are required (for example for reasons of noise reduction), the maximum output current is decreased, in which case the performance category should be specially checked.

**The overall package includes the frequency inverter, filter for class B (for residential and commercial uses) as well as a control unit.**

### General Performance characteristics

Motor protection feature for motors with thermistor temperature sensors, adjustable acceleration and deceleration ramps, minimum and maximum rotation speeds, fixed rotation speeds, trapping switch during operation, programmable inputs and PI-controller (MM420 and MM430 only), RS485 serial interface as well as a detailed operating instructions. Caution about combination with isolators (ESH)! Special EMC-action can be necessary, furthermore do not switch during operation, overvoltages can destroy the switch and the motor-winding.

### Performance range G110 1AC 230V (for single-phase AC supply)

0.25 kW to 2.2 kW rated motor power, 200 V to 240 V 10 % single-phase AC, 47 Hz up to 63 Hz, three-phase current output 3×230 V AC, protection class IP20. Permitted ambient temperature during operation: -10 °C up to +40 °C.

### Performance range MM420 3AC 400V (for three-phase AC supply)

0.55 kW to 11 kW rated motor power, 380 V to 480 V 10 % three-phase AC, 47 Hz up to 63 Hz, three-phase current output 3×400 V AC, protection class IP20. Permitted ambient temperature during operation: -10 °C up to +50 °C. The interference suppression filter required to comply with the EMC basic interference suppression standard EN 50081-1 (residential and commercial uses) is integrated into the package as substructure option. Power choke to comply with EN 61000-3-2 as additional component.

**Observe performance reduction when using high clock frequencies!**

### Performance range MM430 3AC 400V

(for three-phase AC supply)

15 kW to 250 kW rated motor power, 380 V to 480 V 10 % three-phase AC, 47 Hz up to 63 Hz, three-phase current output 3×400 V AC, protection class IP20. Permitted ambient temperature during operation: -10 °C up to +50 °C. The interference suppression filter required to comply with the EMC basic interference suppression standard EN 50081-1 (industrial applications) is partially integrated. In order to attain EMC requirements Class B a frequency inverter without filter should be selected. The appropriate EMC-B filter is then required as an additional component.

**Observe performance reduction when using high clock frequencies!**

The indicated ratings of the units are made for a quick selection. The exact dedication of an inverter in this catalogue is made by taking into account of the max. admitted current at a pulse frequency of 4 kHz. It is important to know that at higher pulse frequencies the supplied current of the inverter will be decreasing, with the possible consequences of having to select a larger inverter unit. Also longer feed lines or additional radio frequency filters may lead to the choice of a larger inverter size.

**The selected frequency inverters (G110 und MM420) are units contains the frequency inverter (as shown in the following tables) with the matching interference suppression filter (Class B) and a control panel. A further component is the line choke which is available as an accessorie.** For more information the available frequency inverters are shown in the following tables.



# Accessories

## Frequency converter

### Technical Data | Dimensions

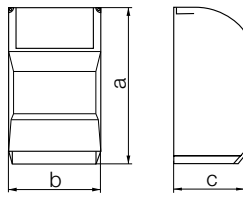

For three-phase AC motors on the single-phase supply.

6SL3211-	Nominal power kW	Nominal current A	a mm	b mm	c mm	Weight kg
0AB12-5BA0	0.25	1.7	150	90	116	0.8
0AB13-7BA0	0.37	2.3	150	90	116	0.8
0AB15-5BA0	0.55	3.2	150	90	131	0.9
0AB17-5BA0	0.75	3.9	150	90	131	0.9
0AB21-1AA0	1.1	6	160	140	142	1.5
0AB21-5AA0	1.5	7.8	160	140	142	1.5
0AB22-2AA0	2.2	11	181	184	152	2.1

### Technical Data | Dimensions

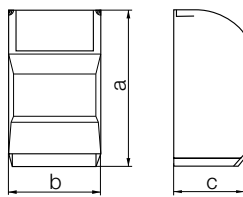

For three-phase AC motors on the three-phase supply

6SE6420-	Nominal power kW	Nominal current A	a mm	b mm	c mm	Weight kg
2UD15-5AA1	0.55	1.6	173	73	149	1
2UD17-5AA1	0.75	2.1	173	73	149	1
2UD21-1AA1	1.1	3	173	73	149	1
2UD21-5AA1	1.5	4	173	73	149	1
2AD22-2BA1	2.2	5.9	202	149	172	3.3
2AD23-0BA1	3	7.7	202	149	172	3.3
2AD24-0BA1	4	10.2	202	149	172	3.3
2AD25-5CA1	5.5	13.2	245	185	195	5
2AD27-5CA1	7.5	18.4	245	185	195	5
2AD31-1CA0	11	26	245	185	195	5

### Technical Data | Dimensions

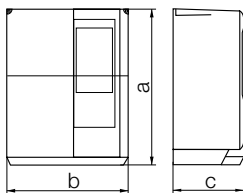

For three-phase AC motors on the three-phase supply

6SE6430-	Nominal power kW	Nominal current A	a mm	b mm	c mm	Weight kg
2AD31-5CA0	15	32	245	185	195	5.7
2AD31-8DA0	18.5	38	520	275	245	17
2AD32-2DA0	22	45	520	275	245	17
2AD33-0DA0	30	62	520	275	245	17
2AD33-7EA0	37	75	650	275	245	22
2AD34-5EA0	45	90	650	275	245	22
2AD35-5FA0	55	110	1150	350	320	75
2AD37-5FA0	75	145	1150	350	320	75
2AD37-8FA0	90	178	1150	350	320	75
2UD41-1FA0	110	180.4	1450	326	356	116
2UD41-3FA0	132	220	1450	326	356	116
2UD41-6GA0	160	265.8	1533	326	545	116
2UD42-0GA0	200	325.6	1533	326	545	116
2UD42-5GA0	250	419.8	1533	326	545	116

# Accessories

## Motor protection unit



Motor protection unit EUM 33

Motor protection unit for three-phase current motors (standard motors) without thermal contacts.

### Design

Plastic casing in protection class IP55, permissible ambient temperature +40 °C, 40 Hz up to 60 Hz, frontal operation, for wall mounting. Motor protection unit for single-speed, non-variable speed three-phase current motors without thermal contacts.

### Function

The motor protection units must be adjusted on site to the trigger current. If the preset trigger current is exceeded, the device disconnects the motor from the mains supply via a thermal overload release. Pressing the "on key" causes the unit to turn on again.

All motor protection units EUM33 are also suitable for the protection of EExe-motors (PTB-Prüfung Gesch-Nr. 3.35/386.3060). They must however be mounted outside of explosion endangered areas, since they are not themselves designed with explosion protection.

### Dimensions in mm, subject to change.

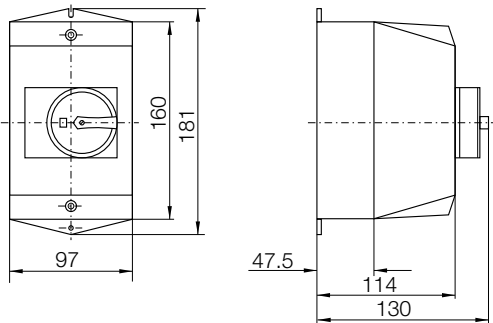

### Technical Data

EUM 33-	Continuous current A	Setting range A	Max. nominal power kW
0004-8D	0.4	+0.2...+0.4	0.09
0006-8D	0.6	+0.4...+0.6	0.12
0010-8D	1.0	+0.6...+1.0	0.25
0016-8D	1.6	+1.0...+1.6	0.55
0024-8D	2.4	+1.6...+2.4	0.8
0040-8D	4.0	+2.4...+4.0	1.5
0060-8D	6.0	+4.0...+6.0	2.5
0100-8D	10	+6.0...+10	4.0
0160-8D	16	+10...+16	7.5
0200-8D	20	+16...+20	9.0
0250-8D	25	+20...+25	12.5
0500-8D	50	+25...+50	25
0580-8D	58	+50...+58	30

### Wiring Diagram

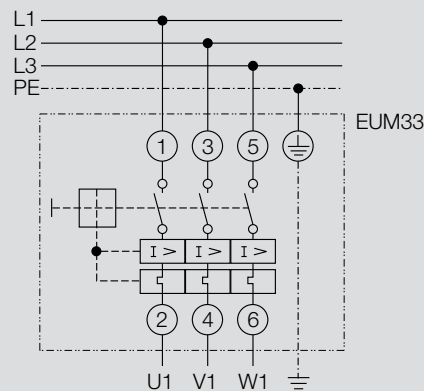

# Accessories

## Universal control device



Universal control device for installation in control cabinets Digital control module for controlling pressure, air velocity or volume flow (PI controller). For example, a transformer for fans is controlled via the 0...10 V output. The device is designed for installation in control cabinets.

### Type

Multi functional LC-display for actual and nominal values (m/s, hPa = mbar, 100 m<sup>3</sup>/h). Menuassisted adjustment via three function keys.

Actual value input 0...10 V e. g. for:

- ▶ air speed sensors Type EIL in measuring ranges from 0...1 m/s and 0...10 m/s e. g. for:
  - Air velocity control in clean room technology.
- ▶ Pressure sensors Type EIP in measurement ranges 50Pa up to 4000Pa e. g. for:
  - Pressure control in canal systems of air conditioning systems (VVS) or
  - Flow control in centrifugal fans with pressure tapings in the inlet cone. The control module calculates the required flow (m<sup>3</sup>/h) from the differential measured pressure between the surrounding level and inlet cone, maximum volume flow 65536 m<sup>3</sup>/h.
- ▶ Output 0...10 V e. g. for controlling a transformer.
- ▶ Failure message is output via display (internal/external) and relay programmable.
- ▶ External set value specification via potentiometer or 0...10 V signal.
- ▶ Specification of two set values (day/night), can be switched over externally or via keyboard.
- ▶ Protection against unauthorised setting by keyboard code.

### Application area

- ▶ Pressure regulation for centralised ventilation systems and variable volume flow systems for building air conditioning (VVS) e.g. in combination with a frequency inverter or a commutation unit or a transformer and a pressure sensor
- ▶ Volume flow regulation for centrifugal fans (with measuring stub in the inlet cone) e.g. in combination with a frequency inverter or a commutation unit or a transformer or a mini-interface inverter and a pressure sensor and the volume flow volumeter. Maximum volume flow 65536 m<sup>3</sup>/h.
- ▶ Air speed regulation for clean room systems, e.g. in combination with a transformer and an air speed sensor

### Electrical connection and installation

Connection to 230 V, 50/60 Hz. The control module can be installed in a control cabinet door. Admissible relative humidity: 85 %, noncondensing. Power supply for the sensors included:

+24 V, 20 %, I<sub>max</sub> = 70 mA.

#### Setting options

- ▶ Set values in the measurement range of the sensor (m/s, hPa = mbar), or in the volume flow range of the fan (×100 m<sup>3</sup>/h)
- ▶ Switch over of set value (day/night)
- ▶ Min./max. setting range
- ▶ Translation of performance curve (P component)
- ▶ Constant of integration can be selected (I component)
- ▶ Reversal of the effect of the control behaviour
- ▶ Rotation of the performance curve
- ▶ Switchover or programming of internal/external set value
- ▶ Sensor selection via keypad
- ▶ Programming for "Filter fault"
- ▶ Keypad code
- ▶ K factor entry (The K-factor can be found in the current lists of our fan line)

### Technical Data

	Input voltage V	Output voltage V	Max. output current mA	Motor protection class	Operating consumption VA	Operating temperature °C
ERA 02-4000-5E	0...10	0...10	10	IP20	10	+0...+40

# Accessories

## Universal control device

Dimensions in mm, subject to change.

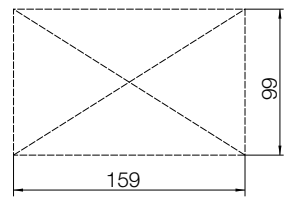
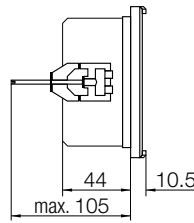
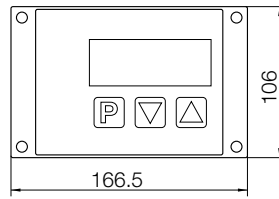

Instrument panel window

## Wiring Diagram

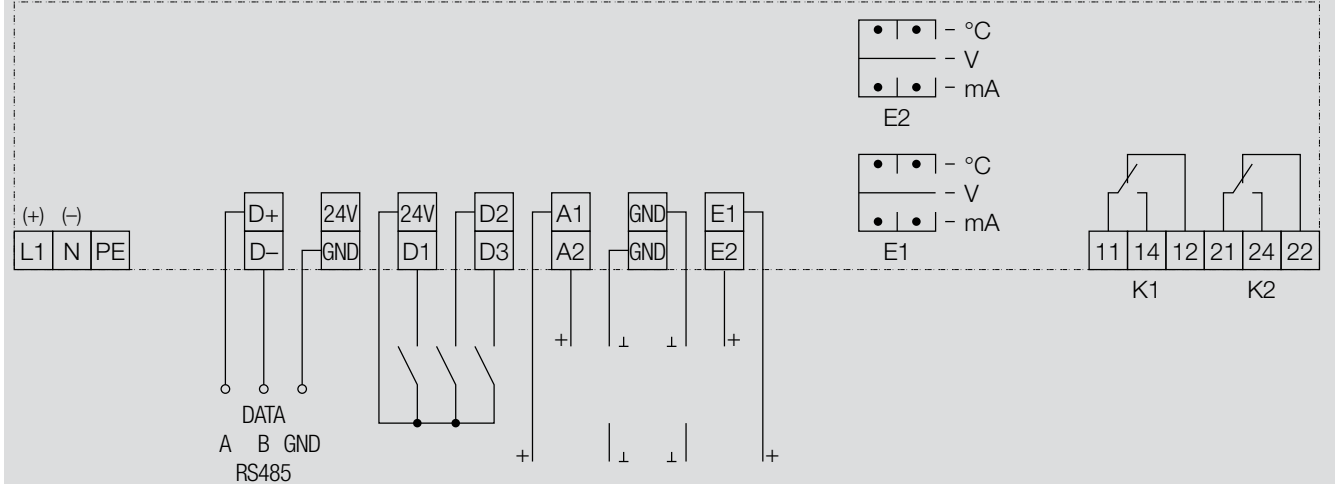

- ① = Mains
- ② = Out, 24 V DC
- ③ = Input, Digital 1/2/3
- ④ = Out, Analog 1/2
- ⑤ = Input, Analog 0-10 V 1/2
- ⑥ = A1 Out 0-10 V
- ⑦ = A2 Out 0-10 V
- ⑧ = E1 Input 0-10 V
- ⑨ = E2 Input 0-10 V
- ⑩ = Contact rating max. 5 A / 250 V AC

# Accessories

## Differential pressure sensor



Differential pressure sensor with membrane for measuring the pressure, negative pressure or differential pressure of nonaggressive gases.

### Type

The differential pressure to be measured acts transformed into an output signal of 0...10 V by electronics (in SMD technology).

### Application ranges

Volume flow regulators in centrifugal fans (with volume flow measuring device IMV) in connection with a frequency inverter type G110, MM420, MM430, or a universal regulator appliance type ERA 02-4000-5E in connection with a frequency regulator.

### Electrical connection and installation

The differential pressure sensor delivers a starting signal (0...10 V) by pressure increase at the "Plus" connection opposite pressure on the "Minus" connection.

#### Voltage supply

- ▶ 15...30 V DC or 24 V AC, 15 %
- ▶ Pressure connections must point downward, tube connection ø5mm

#### Measuring accuracy

- ▶ Null drift: 0.75 %
- ▶ Sum of linearity and hysteresis: 1 %
- ▶ Temperature drift zero point: 0.3 %/10 K
- ▶ Temperature drift length of measurement: 0.2 %/10 K

### Dimensions in mm, subject to change.

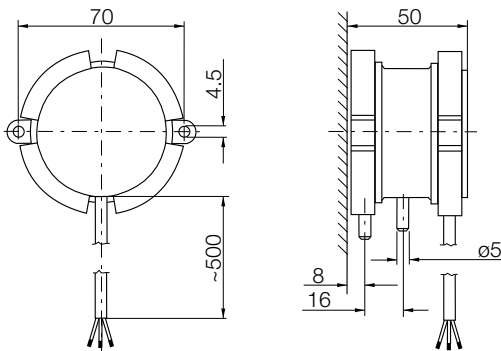

### Technical Data

EIP 01-	Pressure range Pa	Motor protection class	Max. current consumption mA	Overload protection Pa	Output signal proportional V	Operating temperature °C
0200-12	0 ... +200	IP65	12	20000	0 ... +10	0 ... +50
0500-12	0 ... +500	IP65	12	20000	0 ... +10	0 ... +50
1000-12	0 ... +1000	IP65	12	20000	0 ... +10	0 ... +50
2000-12	0 ... +2000	IP65	12	20000	0 ... +10	0 ... +50
4000-12	0 ... +4000	IP65	12	20000	0 ... +10	0 ... +50

### Wiring Diagram

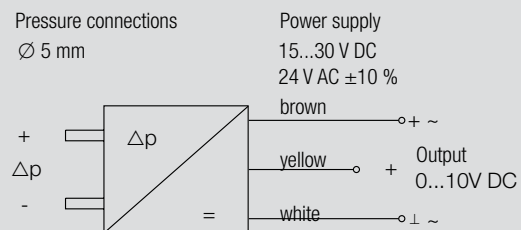

# Accessories

## Isolator ESH 21



Isolator  
ESH 21 (≤3 kW)



Isolator  
ESH 21 (≥5.5 kW)

The isolators are grouped according to motor rated power. All important characteristic data are evident from the model designation. E.g.: **ESH 21-0030-65**  
= 3 kW switch - 6 main contacts - 5 auxiliary contacts

### Design

Beautifully shaped, shock-resistant plastic casing. Protection class IP44/IP65, for sur-face mounting, switching symbols 0 and I. The isolator is fitted with connection terminals that are very accessible and has a con-nection diagram glued in the casing.

The **ESH21 up to 3 kW** is designed to IP44. It is equipped with an integrated locking mechanism.

The **ESH21 up to 5.5 kW** is designed to IP65. It is equipped with a coupling cover and an integrated locking mechanism. A padlock can in some cases be fitted to the rotary switch.

### Function

The isolator disconnects the fan safely from the mains in the event of cleaning, maintenance or repair work on site and thus avoids accidents due to uncontrolled activation of the unit by third parties. It is no main switch or emergency switch.

**All of the classified isolators are fitted with potential-free contacts (1 closer and 1 opener).**

The isolators for motors with a built-in thermal contact have on principle three supplementary auxiliary contacts, so that the pre-switched control device does not drop out during cleaning or servicing work due to motor.

Caution about combination with frequency inverter!

Special EMC-action can be necessary, furthermore do not switch during operation, overvoltages can destroy the switch and the motor-winding.

### Dimensions in mm, subject to change.

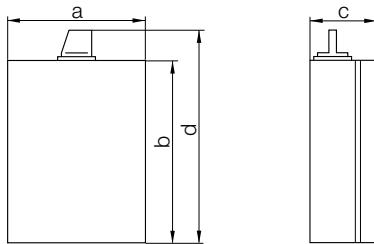

ESH 21 ≤3 kW

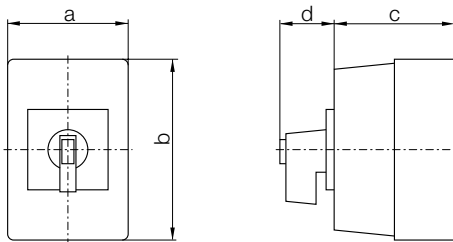

ESH 21 ≥5.5 kW

### Technical Data

ESH 21-	Permissible motor power kW	a mm	b mm	c mm	d
0030-22	3	73	108	45	–
0030-25	3	73	108	45	–
0030-32	3	73	108	45	–
0030-35	3	73	108	45	–
0030-62	3	73	108	45	–
0030-65	3	73	108	45	–
0055-32	5.5	85	120	80	110
0055-65	5.5	125	125	126	157
0075-32	7.5	85	120	80	110
0075-35	7.5	85	120	80	110
0075-62	7.5	100	190	91	133
0075-95	7.5	125	125	126	157
0110-32	11	85	160	80	110
0110-62	11	100	190	91	133
0150-32	15	100	190	91	120
0150-62	15	145	250	100	145
0220-32	22	100	190	91	120
0220-62	22	145	250	100	145
0300-32	30	145	250	100	140
0300-62	30	200	300	172	200
0370-32	37	145	250	100	140
0370-62	37	200	300	172	200
0450-32	45	200	300	172	200
0450-62	45	300	300	172	210
0550-32	55	200	300	172	200
0550-62	55	300	300	172	210
0900-32	90	280	400	180	210
0900-62	90	280	280	260	327

# Accessories

## Isolator ESH 22

### Design

Shock-resistant metal casing, black switch with symbols 0 and I. Protection class IP65 or IP54, for surface mounting (see determination in the tabular).

The isolator is fitted with connection terminals that are very accessible and has a connection diagram glued in the casing.

All isolators are equipped with a coupling cover and an integrated locking mechanism. In some cases a padlock can be fitted to the rotary switch.

### Function

The isolator disconnects the fan safely from the mains in the event of cleaning, maintenance or repair work on site and thus avoids accidents due to uncontrolled activation of the unit by third parties. It is no main switch or emergency switch.

**All of the classified isolators are fitted with potential-free contacts (1 closer and 1 opener).**

The isolators for motors with a built-in thermal contact have on principle three supplementary auxiliary contacts, so that the pre-switched control device does not drop out during cleaning or servicing work due to motor.

### Use

The isolator ESH22 with metal casing is necessary, if screened components must be used. (e.g. frequency inverters or control engineering devices are used featuring electronic components).

### Attention!

Do not switch during operation, overvoltages can destroy the switch and the motor winding!

**Dimensions** in mm, subject to change.

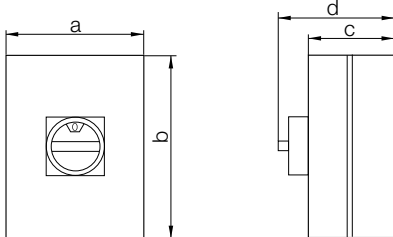

### Technical Data

ESH 22-	Permissible motor power kW	a mm	b mm	c mm	d mm	Cable lead-through (top)	Cable leadthrough (bottom)
0075-32	7.5	122	120	120	120	2×PG21	2×PG21
0110-32	11	122	120	120	120	2×PG21	2×PG21
0150-32	15	180	180	130	130	2×PG21	2×PG21
0220-32	22	180	180	130	130	2×PG21	2×PG21
0300-32	30	230	280	150	150	2×PG29/1×PG16	2×PG29
0370-32	37	230	280	150	150	2×PG36/1×PG16	2×PG36
0075-62	7.5	180	180	130	130	1×PG29/1×PG16	2×PG29
0110-62	11	180	180	130	130	1×PG36/1×PG16	2×PG36
0150-62	15	230	280	150	150	2×PG36/1×PG16	2×PG36
0220-62	22	230	280	150	150	2×PG36/1×PG16	2×PG36
0300-62	30	230	280	150	150	2×PG36/1×PG16	2×PG36
0370-62	37	230	280	150	150	2×PG36/1×PG16	2×PG36
0055-35	5.5	180	180	100	100	2×PG21	2×PG21
0075-65	7.5	116	95	80	80	2×PG16	2×PG16
0075-95	7.5	116	95	80	80	2×PG16	2×PG16

The isolators are grouped according to motor rated power.

All important characteristic data are evident from the model designation. E.g.: **ESH 22-0075-65** = 7.5 kW switch - 6 main contacts - 5 auxiliary contacts

# Description

## Safety

The fans are designed for installation in equipment and as standard are not equipped with protective guards.

**They should not be put into operation before all protective devices are fitted and connected!**

Protective measures must be carried out as set out in DIN EN ISO 12100 "Safety of machinery - Basic concepts, general principles for design".

If the application of the fan allows free access to the inlet and discharge apertures, safety devices must be put in place on the fan in accordance with DIN EN ISO 13857! Suitable safety guards are available as an optional extra.

## Performance data

The performance curves of the fans are determined at the plenum test rig according to ISO 5801, measured in installation "B".

In the diagrams of all series, the total pressure increase  $p_F$  and the dynamic pressure in relation to the flange crosssection at the discharge  $p_{d2}$  are represented in dependency on the volume.

For closer determination of duty same unit performance curves (parabolas) are contained in the diagrams.

The static pressure increase  $p_{sF}$  with a connected discharge flange can be determined according to the following relation:

$$p_{sF} = p_F - p_{d2}$$

All data are valid for the source density  $\rho_1 = 1.2 \text{ kg/m}^3$ .

## Sound

The noise measuring and evaluation is conducted according to DIN 45635-38 "Noise measurement in machines: fans".

In the diagrams the A-weighted sound power level of the fan is given on the performance curves as the emission size.

The "A" weighted sound power level are identical for fan intake ( $L_{WA7}$ ) as well as for fan discharge ( $L_{WA4}$ ).

The A-weighted sound pressure level  $L_{pA7/6}$  at a distance of 1 m at fan Inlet or discharge can be approximately determined by the following formula:

$$L_{pA6/7} \sim L_{WA4/7} - 7\text{dB}$$

The sound power levels in the individual octavos can be taken from the electronic catalogue "proSELECTA II".

## Media

The series of centrifugal fans, with single inlet are designed for the use in air handling and ventilation installations.

The fans are suitable for conveying air and other non aggressive gases. The temperatures admitted for the fluid are from  $-20 \text{ }^\circ\text{C}$  to  $+60 \text{ }^\circ\text{C}$ .

## Motors

Standard motors of wellknown brands, type of protection IP55, thermal class F, are used. During commissioning and maintenance the detailed instructions provided by the motor manufacturer (type plate/motor operating instructions) must be followed, this also applies to the motor protection devices required onsite. The motors are equipped with PTC resistors/temperature sensors as standard. Motors with integrated frequency inverters may be supplied on request.

## Electric connection

The centrifugal fans are delivered ready for installation.

The motor terminal box can be accessed easily.

Electric installation must be carried out according to the applicable provisions in compliance with local regulations. A terminal board circuit diagram showing correct connection is enclosed with every motor.

Updated circuit diagrams are also available online at [www.nicotra-gebhardt.com](http://www.nicotra-gebhardt.com).

In case of operation with frequency inverters, always follow the respective operating instructions!



# Description

## Explosion protection according to ATEX



Fans for use in explosive atmospheres must comply with EC Directive 94/9/EG (ATEX 95). Equipment in Group II (all applications except mining) is categorised in accordance with the required degree of safety for designated use in equipment categories 1, 2 and 3. Depending on suitability, a distinction is in addition made between G (gas, vapours) and D (dust).

Harmonised European standards and national guidelines must be observed. Equipment in class 2 and 3 is not subject to compulsory specifications nor to type testing. The manufacturer declares conformity with the EC directive.

### For the standard designs of our fans, the following ignition sources are essentially to be considered:

- ▶ Hot surfaces, e.g. due to heat of friction or seizure of a bearing or due to blockage of an impeller
- ▶ Rubbing-, grinding- or beating sparks, e. g. as a result of contact of the impeller with stationary components
- ▶ Sparks resulting from discharge of electrostatically loaded, non-conducting components, e. g. of plasticpanels, surfaces with strong layer thickness.

### Preconditions for operating:

- ▶ In the proximity of the motor, the temperature limits -20 °C and +40 °C must not be exceeded.
- ▶ The temperature limits of -20 °C und +60 °C for the flow medium must not be exceeded. If the temperature of the flow medium should exceed +60 °C on the pressure side, then the fan must be switched off!
- ▶ The fans may only be employed with a horizontal shaft.
- ▶ The fans are to be protected against the falling-in or sucking-in of foreign objects. Protection guards must be ordered separately as an accessories.
- ▶ On the machine plate the max. permitted fan speed is indicated.
- ▶ Fans for operation in ex-hazardous areas are marked as such on the machine plate and they are accompanied by an EU conformity declaration and with operation and maintenance instructions

*The operation and maintenance instructions have strictly to be observed.*

## Quality management system

### DIN EN ISO 9001

Nicotra Gebhardt quality is the result of a continuous company policy intended to guarantee that our product properties and features are clearly superior to comparable products.

This already established company maxim led in April 1985 to the auditing and certification of the existing quality management system. In the following years it was updated to match the changing international and European standards. Modern production processes, monitored by our quality management system, guarantee a high repeat accuracy in production.

This ongoing high standard of quality permits the establishing of the performance data in classes of accuracy in accordance with DIN 24166.

The narrow tolerances ensure a high level of data reliability for our products.

## Machine Safety

The fans contained in this catalogue are not machines in the sense of the EC Machine Directive. They are delivered with a manufacturer "Declaration of incorporation".

The assessment of the dangers associated with the fan and necessary safety measures are based on the VDMA Unit sheet 24167 : Fans; Safety requirements.

The operating instructions give which safety measures are still necessary on assembly to ensure that the fans comply with the Machine Directive 2006/42/EC.

## Catalogue data

We reserve the right to change any measurements and technical data in this catalogue in accordance with further development of our products. All information valid at the time of printing.

# Notes

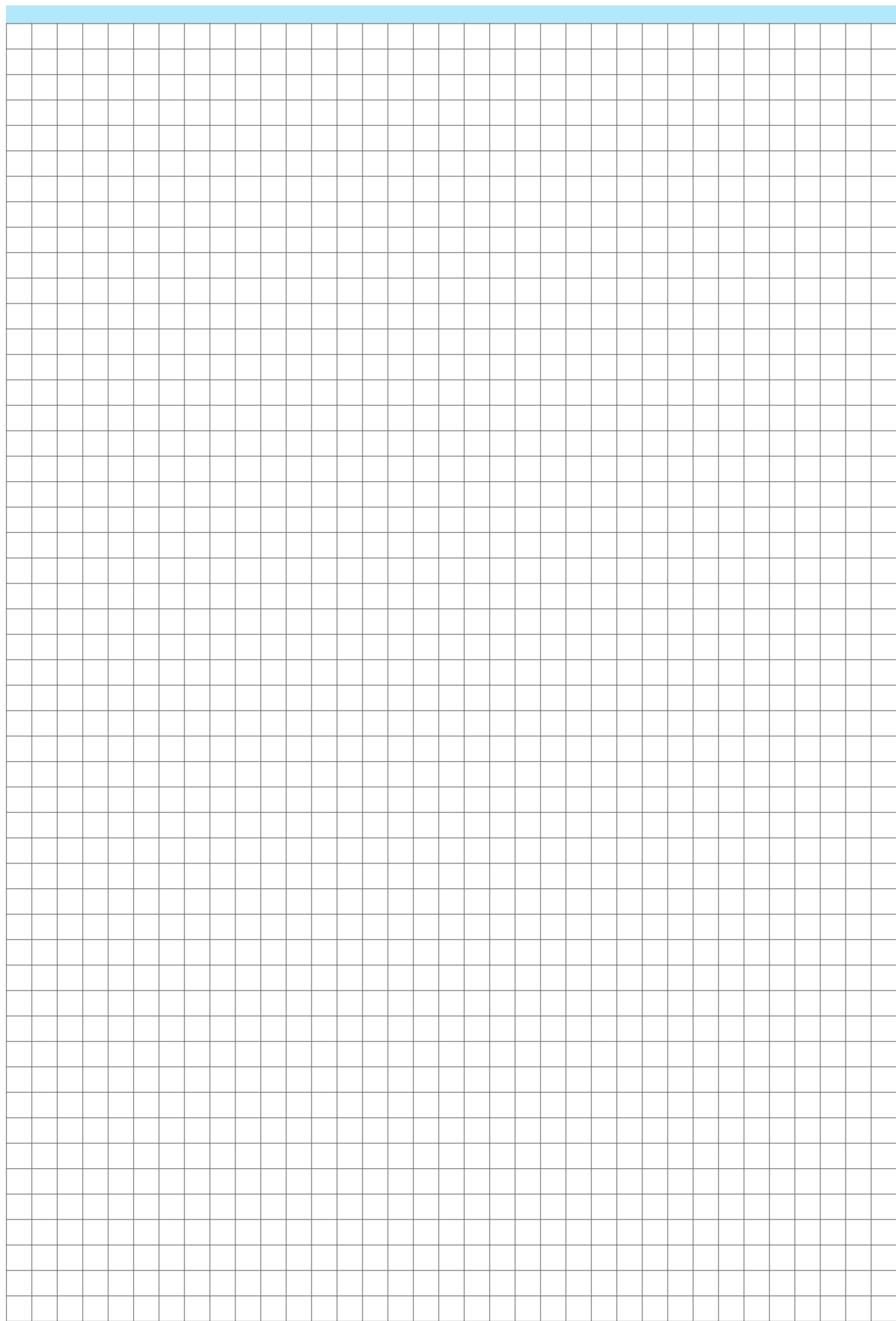

# Notes

